

MX-K Series

인덱싱 전용 (FOR INDEXING APPLICATIONS ONLY)

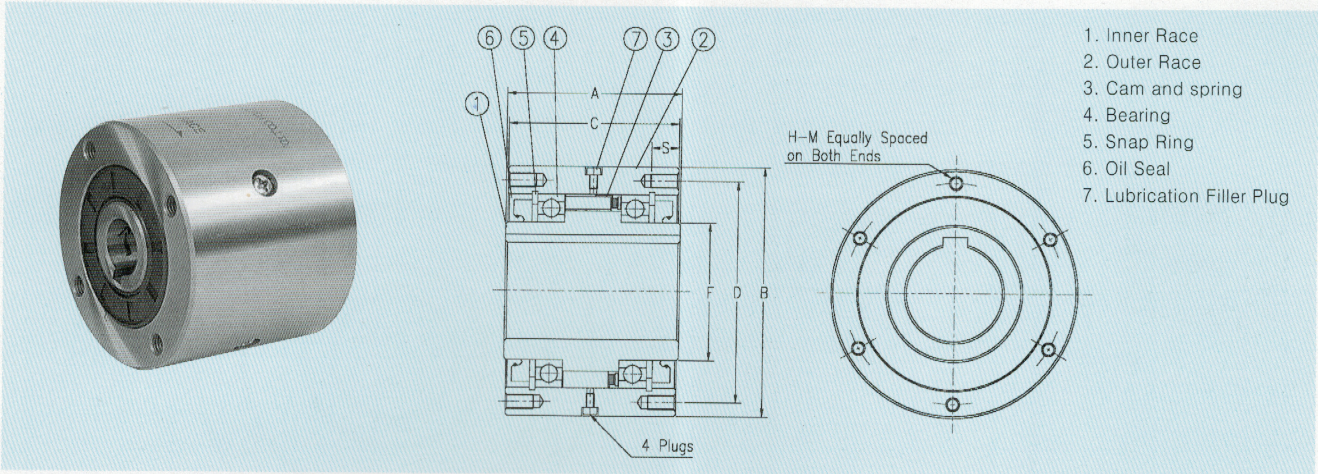

■ 사양 (Specification)

Model	Max. Torque (kgf-m)	Max. Indexing (cycle/min)	Stock Bore Size		A	B (h7)	C	D	F	S	H-M No. of Tapped holes Dia×Pitch	Lubrication Filler Plug Dia×Pitch	GD ² Inner Race (kgf-m ²)	Over-running Drag (kgf-m)	Oil (CC)	Weight (kgf)
			Dia (H7)	Keyway												
MX 22K	8	1,200	22	6×2.8	80	95	77	80	35	16	4×M8×1.25	M6×1.0	0.0006	0.048	80	3.3
MX 35K	24	1,200	35	10×3.3	90	125	87	110	50	16	4×M8×1.25	M6×1.0	0.0025	0.139	110	5.2
MX 50K	45	1,200	50	14×3.8	100	155	97	140	70	16	6×M8×1.25	M8×1.25	0.011	0.273	190	10.2
MX 70K	80	1,200	70	20×4.9	127	200	124	180	100	20	6×M10×1.5	M8×1.25	0.052	0.525	340	21.3

■ 특징

1. 설치시, 풀리, 기어, 토크암의 허브 내경에 크러치를 끼우고 고압볼트로 확실히 고정시킨다.
2. 축과 내륜과의 맞물림은 최대 끼워맞춤 공차 0.025 mm까지 해야한다.
3. 정확한 인덱싱 실행을 위해서는 브레이크장치와 역전방지장치인 크러치가 필요하다.

■ Character

1. For installation, insert the clutch into hub bore of the pulley, gear or torque arm and screw bolts (high tension) tightly.
2. A press fit do not exceed 0.025mm.
3. A braking device and a back stopping device may be required for accurate performance.

설치에 (application)

