

B200K Series

샤프트 직결형 (SHAFT MOUNTED TYPE)

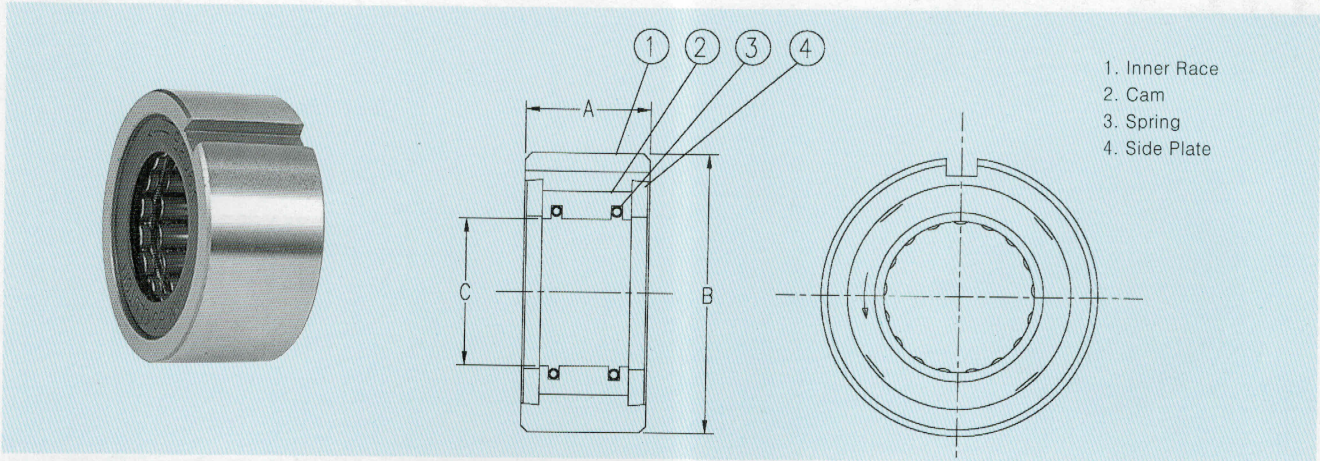

- 1. Inner Race
- 2. Cam
- 3. Spring
- 4. Side Plate

■ 사양 (Specification)

Dimensions—mm

Model	Max Torque (kgf-m)	Nominal Overrunning Drag (kgf-m)	Max. Overrunning (rpm)		Max. Indexing (cycle/min)	A ⁺⁰ / _{-0.06}	B	Shaft Dia ⁺⁰ / _{-0.025}	Keyway	Bearing Number	Weight (kgf)
B203K	4	0.01	2,400	500	150	25.0	40 ^{-0.014} / _{-0.039}	16.510	4×2.5	6203	0.23
B204K	6	0.01	2,400	500	150	25.0	47 ^{-0.014} / _{-0.039}	18.796	5×3	6204	0.34
B205K	10	0.02	1,800	400	150	25.0	52 ^{-0.017} / _{-0.042}	23.622	5×3	6205	0.285
B206K	24	0.02	1,800	350	150	28.0	62 ^{-0.017} / _{-0.042}	32.766	7×4	6206	0.68
B207K	38	0.02	1,800	300	150	28.0	72 ^{-0.017} / _{-0.042}	42.088	7×4	6207	0.80
B208K	56	0.02	1,800	200	150	32.0	80 ^{-0.017} / _{-0.042}	46.761	10×4.5	6208	0.91
B209K	56	0.02	1,800	200	150	32.0	85 ^{-0.020} / _{-0.045}	46.761	10×4.5	6209	0.95
B210K	80	0.03	1,200	200	150	32.0	90 ^{-0.020} / _{-0.045}	56.109	10×4.5	6210	1.00
B211K	80	0.03	1,200	200	150	32.0	100 ^{-0.020} / _{-0.050}	56.109	10×4.5	6211	1.40
B212K	125	0.03	1,200	180	150	42.0	110 ^{-0.020} / _{-0.050}	70.029	10×4.5	6212	1.80
B213K	125	0.03	1,200	180	150	42.0	120 ^{-0.020} / _{-0.050}	70.029	10×4.5	6213	2.30
B214K	142	0.04	1,000	180	150	42.0	125 ^{-0.024} / _{-0.060}	79.356	12×4.5	6214	2.40

■ 특징

1. B200K 시리즈는 샤프트 직접 체결형임.
2. 볼 베어링(62계열)과 외경치수가 같으며, 설치시 반드시 베어링과 함께 조립이 되어야 한다. (아래그림 참조)

■ Character

1. 200K Series are shaft mounted directly.
2. Clutch have the same O.D as the ball bearing. for installation of clutch, shaft must be supported by bearings. (refer the below drawing)

설치에 (application)

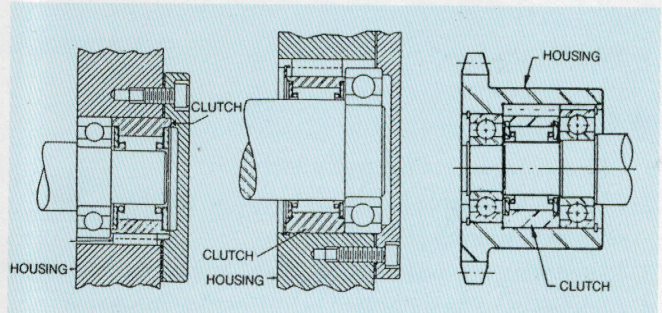

모델별 하우스 내경 공차

Model	Tolerance of housing bore
B203K, B204K	0 to +0.025
B205K, B206K, B207K, B208K	0 to +0.030
B210K, B211K, B212K, B213K	0 to +0.035
B214K	0 to +0.040