



Helical Gear



Farm Feeding Gear



Shaft Mount Gear



Hypoid Gear



Helical Bevel Gear



Helical Worm Gear

ผู้นำเข้าและจัดจำหน่าย :

บริษัท ยูโรแมค คอร์ปอเรชั่น จำกัด
EUROMACH CORPORATION CO., LTD.

545 ถ.เลียบคลองภาษีเจริญ ฟังเหนือ แขวงหนองแขม เขตหนองแขม กทม. 10160
545 North-Leabklongpasricharoen Rd., Nongkhame, Bangkok 10160, Thailand.

โทร. 662-812-0371-5, 662-812-2984 (Auto)
แฟกซ์ 662-812-3995, 662-812-0299

www.euromachthailand.com



High Quality Gear and Motor

FRV Worm Gear UD Variator



www.moderna-motori.com

TABLE OF CONTENTS

■ FRV Worm Gear Box

Summary	3
Dimensions : Single Worm (FRV)	6
Dimensions : Helical Worm (FRV/PC)	16
Dimensions : Double Worm (FRV/FRV)	17
Dimensions : Accessories	18-23
Performance :FRV, FRV/FRV, FRV/PC	24-37

■ UD Variator

Summary	38
Performance : UD, Helical Gear/UD, FRV/UD	39-40
Dimensions : UD	41
Dimensions : Helical Gear/UD	42-43
Dimensions : FRV/UD	44-45

■ Lubrication

B5 & B14 Motor's Dimension	47
----------------------------	----

FRV Worm Gear box

New compact design for strong universal mounting, smooth running, low noise, excellent cooling ventilation, easy maintenance and long life.

1. Body in die cast Aluminum Alloy (light weight) up to size 90 and in cast iron from size 110-150
2. Epoxy polyester painted on the body to prevent oxidation and rust, easy to clean, good looking in the long run.
3. High quality Bronze worm wheel Cu (12-2), Alloy steel worm shaft (20 Cr Mn Ti) case hardened tempered and profile ground for longer service life.
4. Already Filled with synthetic oil for size 25-90 (with plug) in quantity for all mounting position and mineral oil for size 110-150 (with plug and breather) in quantity for B3 mounting position.
5. NAK viton seal or SKF oil seal for input, NAK oil seal for output for better performance and excellent oil leakage protection.

PC Pre-stage Helical gearbox.

PC fitted to a FRV gearbox to be a Helical - Worm gear box, giving higher ratio, higher O/P torque and higher efficiency. PC made from die cast Aluminium Alloy body filled with synthetic long life oil for all mounting position, gear of Alloy steel hardened and tempered.

FRV / FRV Double Worm gearbox.

When combined one FRV connect with another FRV, It will become a Double Worm gear box, It will achieve very high reduction ratio, very low O/P speed, both gear boxes properties are the same as each FRV stand alone and Independent lubricated.

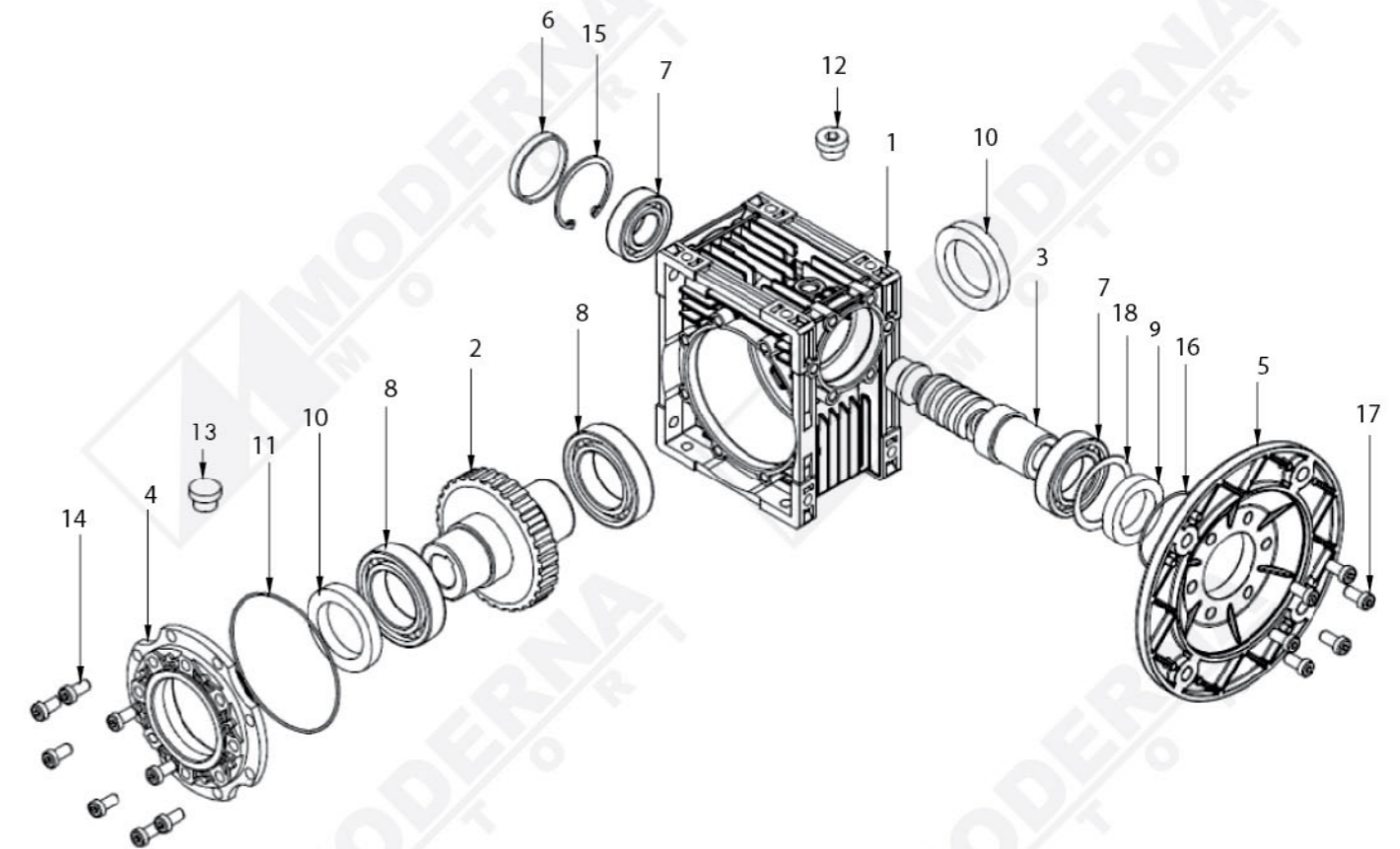

FRV Series Reducer

No.	Parts
1	Frame
2	Worm wheel
3	Worm shaft
4	Output shaft cover
5	Flange
6	seal cover
7	Bearing
8	Bearing
9	Oil seal

No.	Parts
10	Oil seal
11	O ring
12	Oil plug
13	Vented plug
14	Inll.hex screw
15	Snap ring
16	O ring
17	Inll.hex screw
18	Shim

Symbols

PAM	=	Fitted for motor coupling	
P1	=	Power of input shaft	(kW)
M2	=	Torque of output shaft	(Nm)
n1	=	Speed of input shaft	(1/min)
n2	=	Speed of output shaft	(1/min)
i	=	Reduction ratio	
f.s	=	Service factor	
Fr1	=	The maximum admitted radial load of input shaft	(N)
Fr2	=	The maximum admitted radial load of input shaft	(N)
η	=	Efficiency	

Radial loads

The radial load on the shaft is calculated with the following formula:

$$Fr = \frac{2000 \times M \times fz}{D} \leq Fr' \text{ or } Fr2$$

Fr	(N)
Resulting radial load	
M	(Nm)
Torque of the shaft	
D	(mm)
Diameter of the transmission member mounted on shaft	
fz =	1.1 Gear pinion
	1.4 Chain wheel
	1.7 V-pulley
	2.5 Flat pulley

Service factor

The service factor (f.s) depends on the operating conditions the reduction unit is subjected to. The parameters that need to be taken into consideration to select the most adequate service factor correctly comprise:

- Type of load of the operated machine: A-B-C
- Length of daily operating time: hours/day (Δ)
- Start-up frequency: starts/hour (\blacksquare)

Type of load: A - uniform
B - moderate shocks
C - heavy shocks

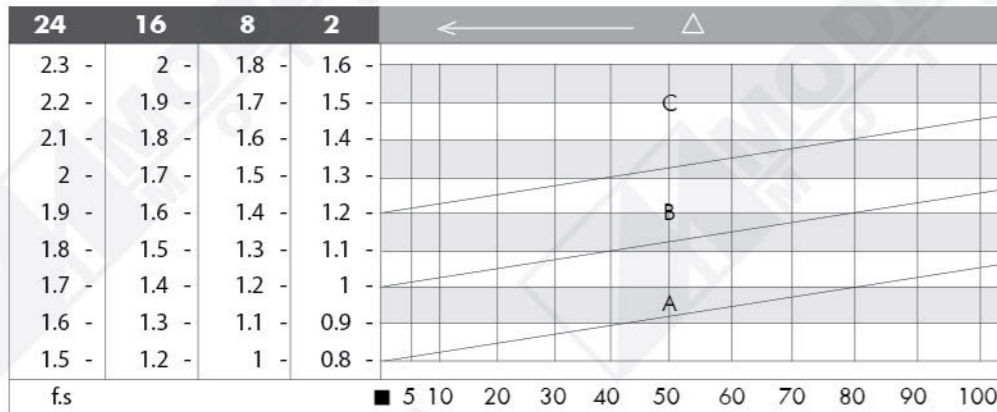

Mounting positions of worm reducer

B3			
B6			
B7			
B8			
V5			
V6			

Dynamic Inreversibility

While running then stop with no more input power, the worm gear will lock if $\eta_d < 0.5$

Static Inreversibility

When standstill, then applied force at output shaft to move the input worm shaft, the worm gear will lock when $\eta_s < 0.5$

When $\eta_s > 0.5$ or $\eta_d > 0.5$, the greater value make the locking ability lower

Mesh parameter

	i	7.5	10	15	20	25	30	40	50	60	80	100
25	Z ₁	4	3	2	2	2	1	1	1	1		
	M _n	1.3	1.3	1.3	0.995	0.8	1.3	0.995	0.8	0.67		
	Y	25°18'	19°31'	13°18'	11°02'	9°05'	6°44'	5°34'	4°34'	3°55'		
	$\eta_d(1400)$	0.85	0.83	0.79	0.75	0.71	0.67	0.62	0.58	0.55		
30	Z ₁	4	3	2	2	1	1	1	1	1	1	
	M _n	18°55'	14°25'	9°44'	7°50'	5°33'	4°54'	3°55'	3°17'	2°43'	2°07'	
	Y	1.44	1.44	1.44	1.1	1.7	1.44	1.1	0.89	0.74	0.56	
	$\eta_d(1400)$	0.85	0.82	0.77	0.73	0.68	0.65	0.59	0.55	0.51	0.44	
40	Z ₁	4	3	2	2	2	1	1	1	1	1	1
	M _n	2.05	2.05	2.05	1.56	1.27	2.05	1.56	1.27	1.06	0.8	0.65
	Y	23°54'	18°23'	12°30'	10°03'	8°45'	6°19'	5°04'	4°24'	3°42'	2°52'	2°29'
	$\eta_d(1400)$	0.87	0.85	0.82	0.78	0.75	0.7	0.65	0.62	0.58	0.52	0.47
50	Z ₁	4	3	2	2	2	1	1	1	1	1	1
	M _n	2.56	2.56	2.56	1.95	1.58	2.56	1.95	1.58	1.32	1	0.8
	Y	23°49'	18°19'	12°27'	10°03'	8°33'	6°18'	5°04'	4°18'	3°38'	2°52'	2°17'
	$\eta_d(1400)$	0.88	0.86	0.82	0.79	0.76	0.72	0.67	0.63	0.59	0.53	0.49
63	Z ₁	4	3	2	2	2	1	1	1	1	1	1
	M _n	3.25	3.25	3.25	2.48	2	3.25	2.48	2	1.68	1.27	1.02
	Y	24°31'	18°53'	12°51'	10°29'	8°45'	6°30'	5°17'	4°24'	3°49'	2°59'	2°26'
	$\eta_d(1400)$	0.88	0.87	0.83	0.81	0.78	0.74	0.7	0.66	0.62	0.57	0.51
75	Z ₁	4	3	2	2	2	1	1	1	1	1	1
	M _n	3.95	3.95	3.95	3	2.42	3.95	3	2.42	2.03	1.54	1.24
	Y	26°38'	20°37'	14°05'	11°19'	9°29'	7°09'	5°43'	4°46'	4°01'	3°17'	2°44'
	$\eta_d(1400)$	0.89	0.88	0.85	0.82	0.8	0.76	0.72	0.69	0.65	0.6	0.55
90	Z ₁	4	3	2	2	2	1	1	1	1	1	1
	M _n	4.84	4.84	4.84	3.69	2.98	4.84	3.69	2.98	2.5	1.89	1.52
	Y	29°05'	22°39'	15°33'	12°50'	10°53'	7°55'	6°30'	5°29'	4°46'	3°45'	3°06'
	$\eta_d(1400)$	0.9	0.89	0.86	0.84	0.82	0.78	0.75	0.72	0.68	0.63	0.59
110	Z ₁	4	3	2	2	2	1	1	1	1	1	1
	M _n	5.875	5.875	5.875	4.62	3.73	5.875	4.62	3.73	3.13	2.37	1.91
	Y	28°15'	21°57'	15°02'	14°42'	12°33'	7°39'	7°29'	6°21'	5°33'	4°27'	3°46'
	$\eta_d(1400)$	0.9	0.89	0.86	0.85	0.84	0.79	0.78	0.75	0.72	0.67	0.63
130	Z ₁	4	3	2	2	2	1	1	1	1	1	1
	M _n	6.97	6.97	6.97	5.4	4.37	6.97	5.4	4.37	3.67	2.77	2.23
	Y	28°43'	22°20'	15°19'	13°47'	11°54'	7°48'	7°00'	6°01'	5°16'	4°07'	3°27'
	$\eta_d(1400)$	0.91	0.89	0.87	0.86	0.84	0.8	0.78	0.75	0.72	0.68	0.64
150	Z ₁	6	4	3	2	2	2	1	1	1	1	1
	M _x	5.5	6.155	5.5	6.155	5	4.193	6.155	5	4.193	3.17	2.55
	Y	32°09'	24°35'	17°27'	12°53'	11°19'	9°50'	6°32'	5°43'	4°57'	3°55'	3°14'
	$\eta_d(1400)$	0.91	0.9	0.88	0.86	0.84	0.83	0.78	0.76	0.73	0.68	0.64
	η_s	0.73	0.71	0.66	0.6	0.57	0.54	0.45	0.42	0.39	0.33	0.29

Mounting positions of double stage worm reducer

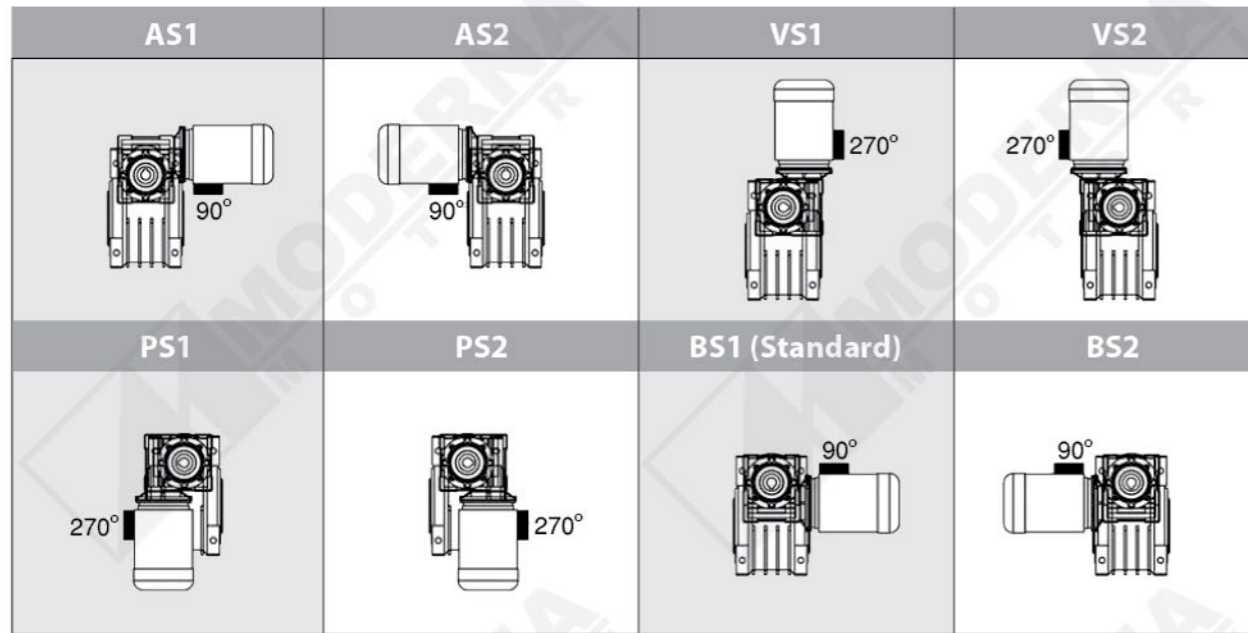

025 Dimensions

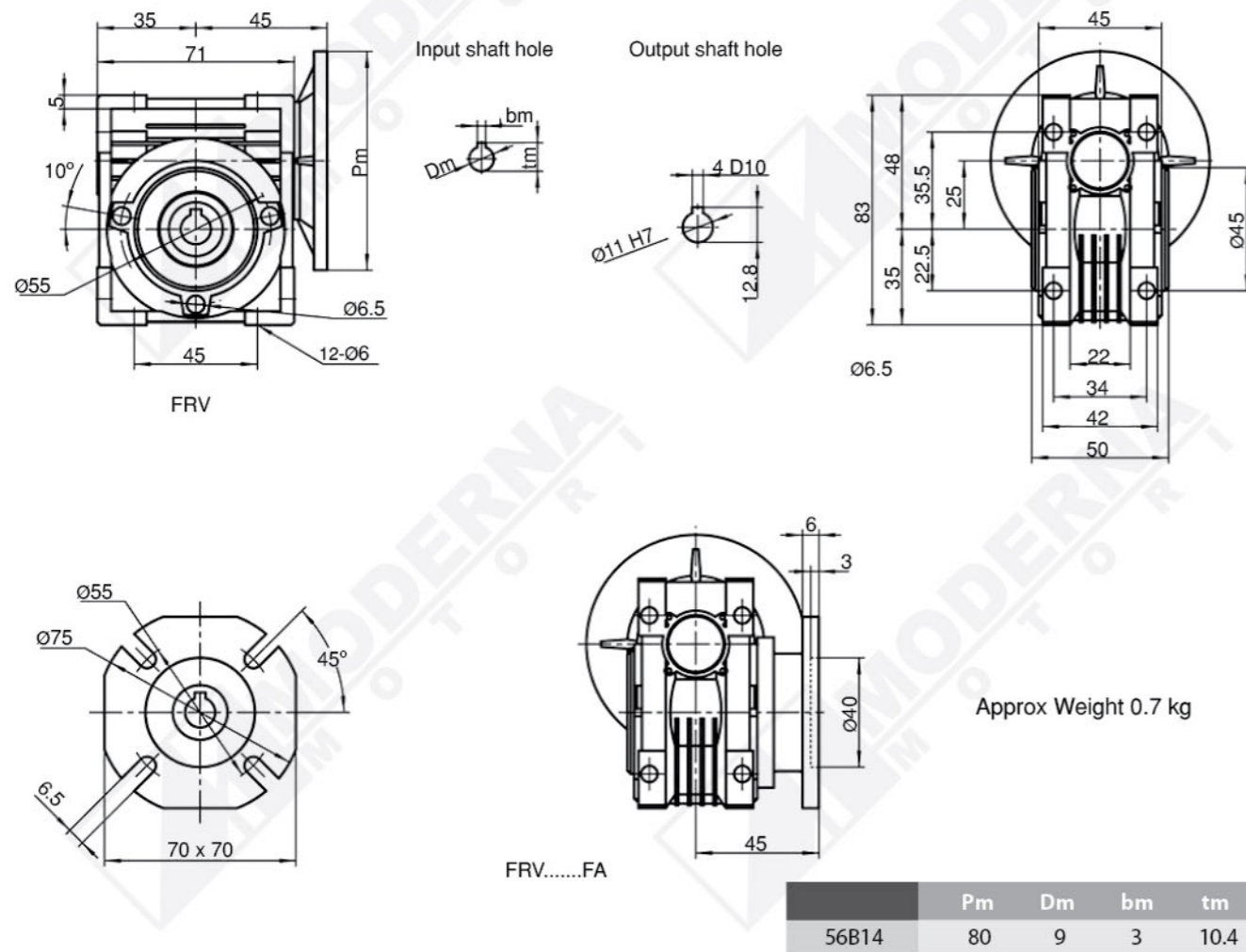

030 Dimensions

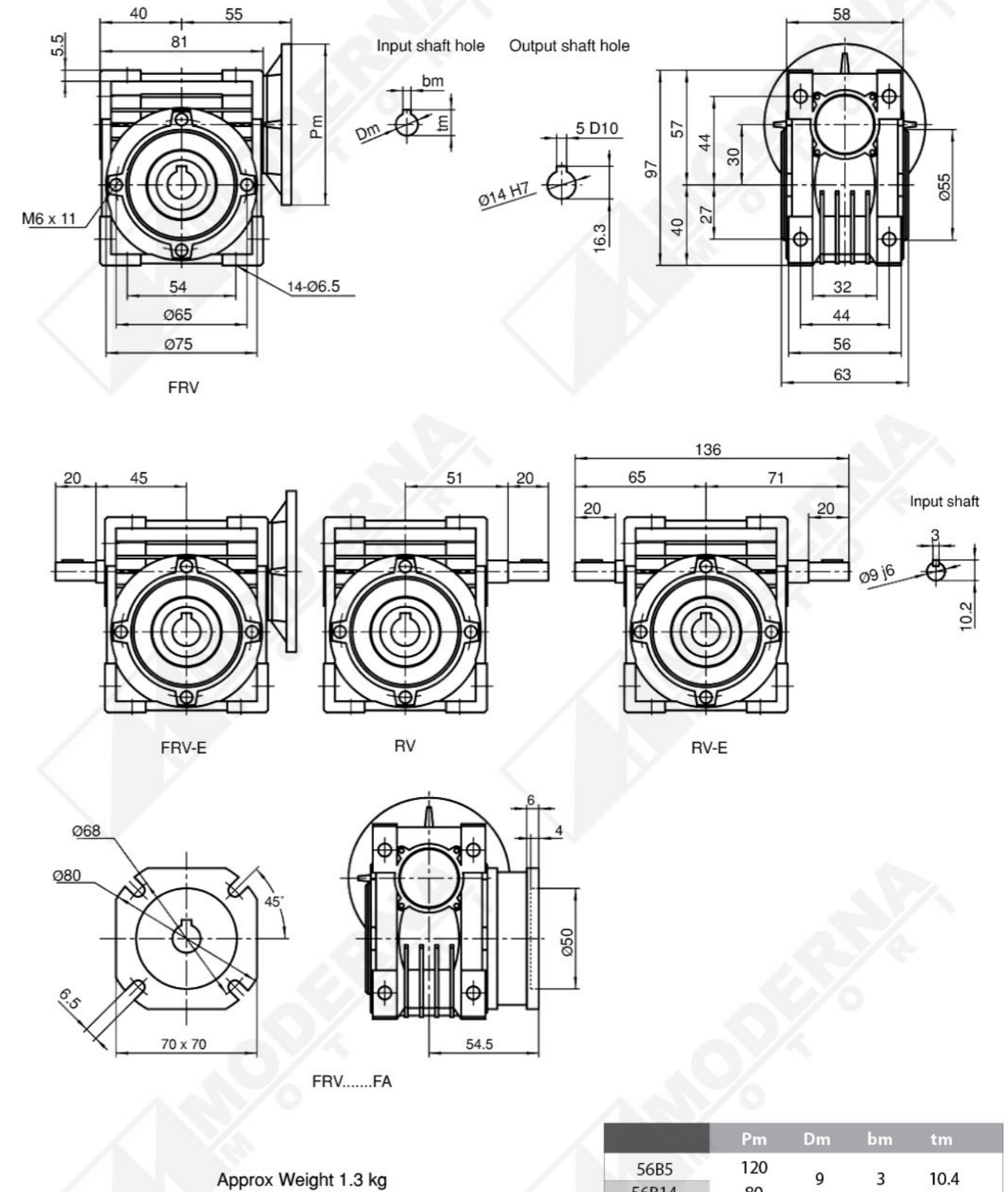

040 Dimensions

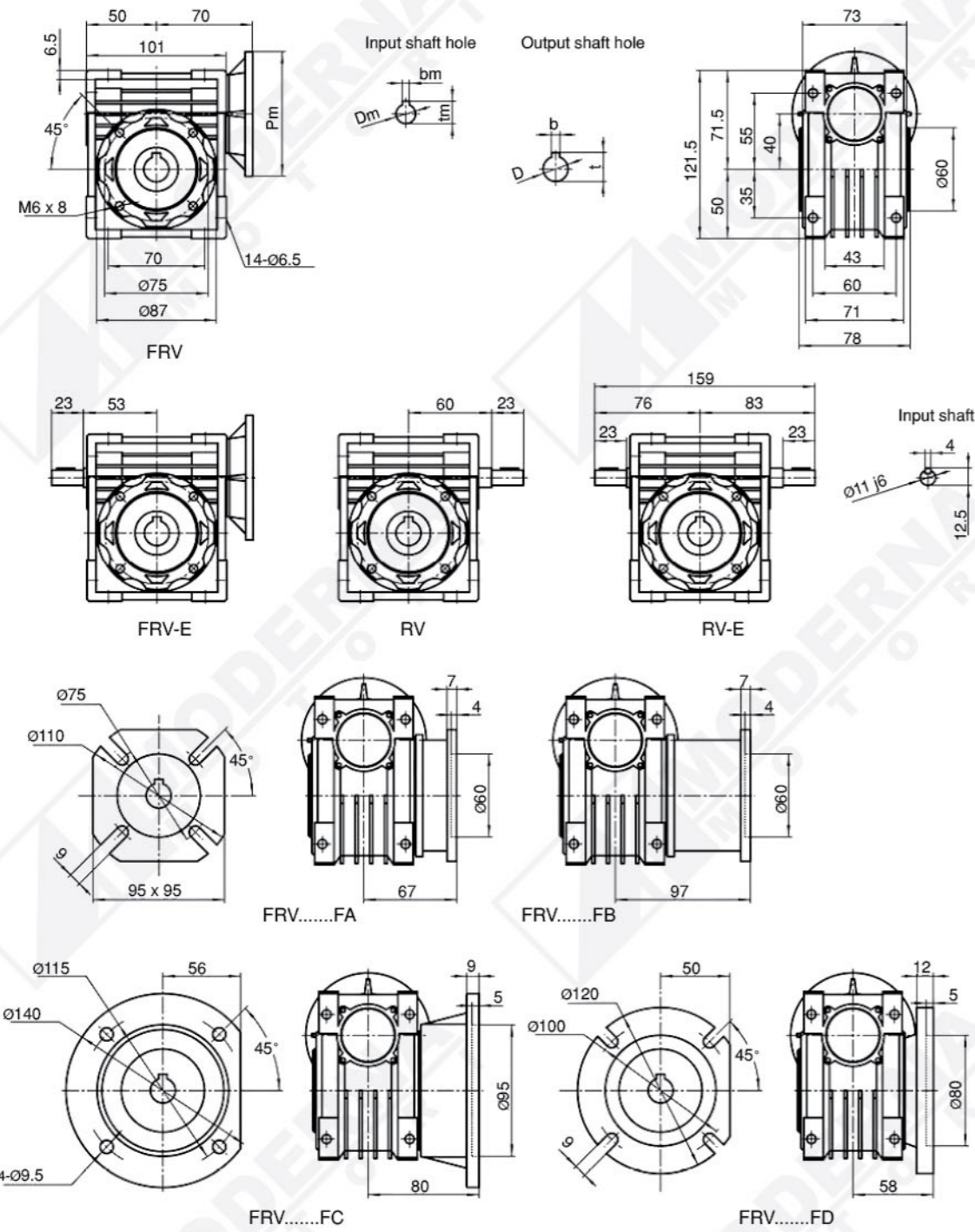

Approx Weight 2.3 kg

Dimensions of output shaft		
D H7	b D10	t
18	6	20.8
(19)	(6)	(21.8)

	Pm	Dm	b _m	t _m
56B5	120	9	3	10.4
63B5	140	11	4	12.8
63B14	90	11	4	12.8
71B5	160	14	5	16.3
71B14	105	14	5	16.3

050 Dimensions

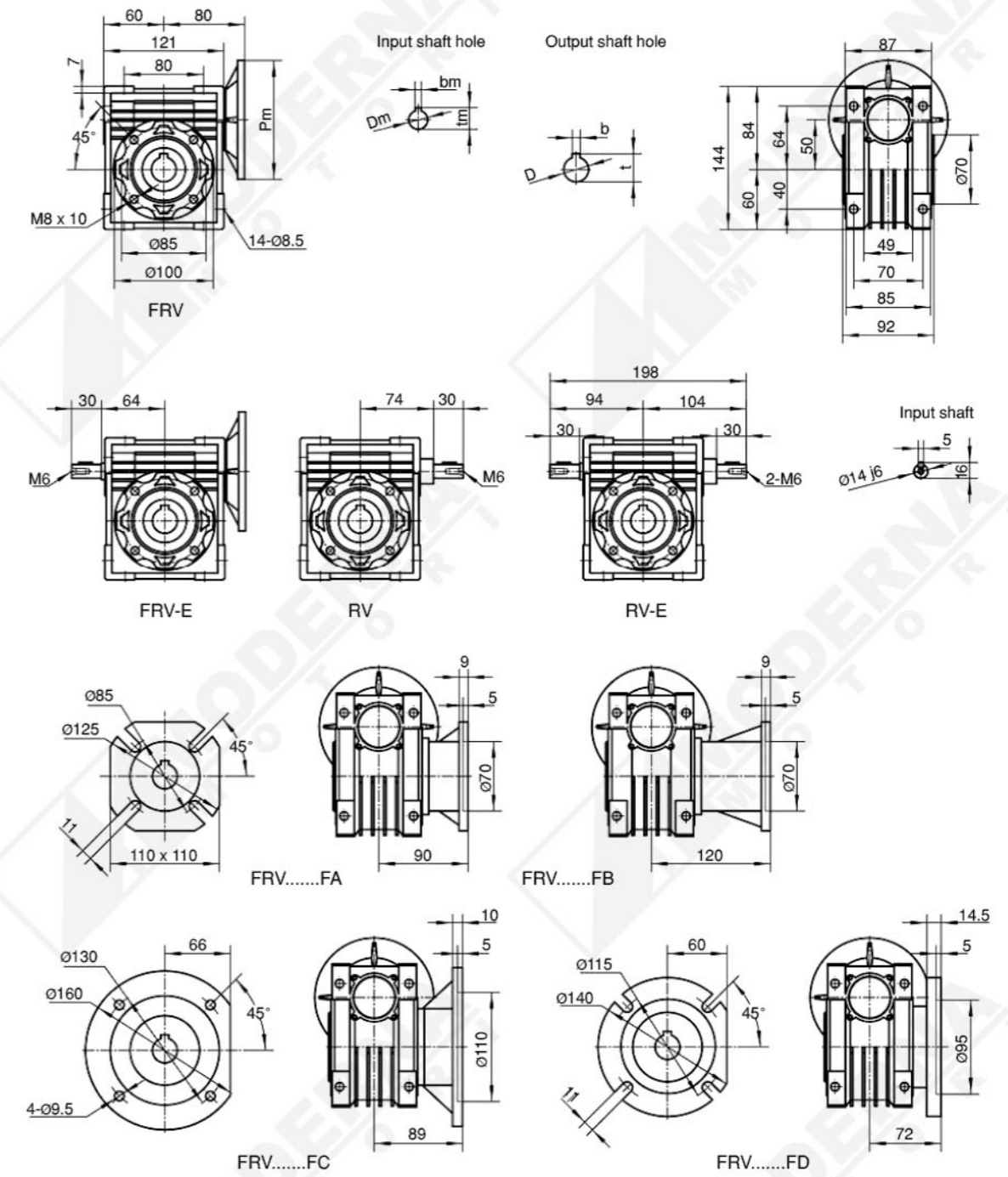

Approx Weight 3.5 kg

Dimensions of output shaft		
D H7	b D10	t
25	8	28.3
(24)	(8)	(27.3)

	Pm	Dm	b _m	t _m
63B5	140	11	4	12.8
63B14	90	11	4	12.8
71B5	160	14	5	16.3
71B14	105	14	5	16.3
80B5	200	19	6	21.8
80B14	120	19	6	21.8

063 Dimensions

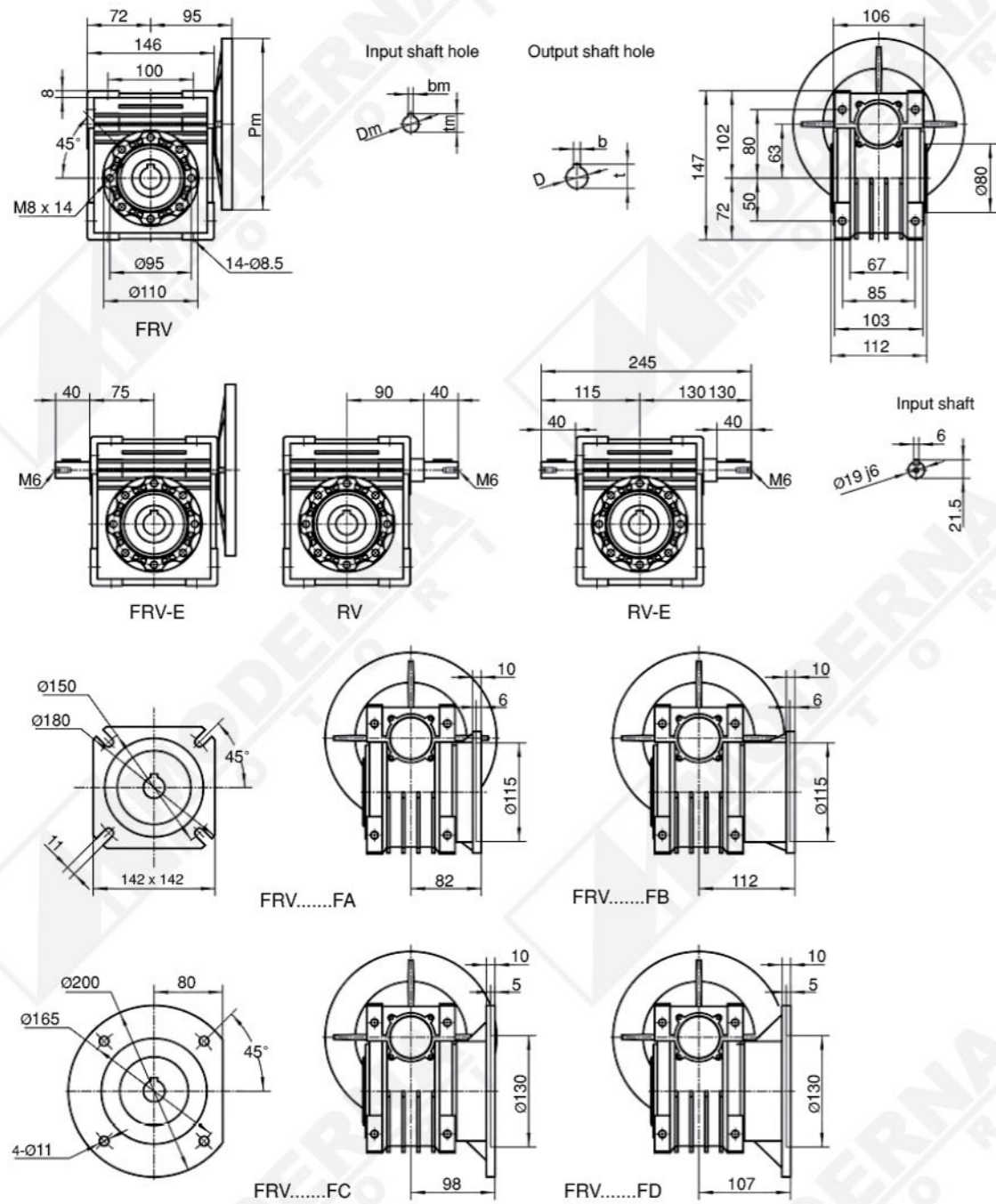

Approx Weight 6.2 kg

Dimensions of output shaft		
DH7	b D10	t
25	8	28.3
(28)	(8)	(31.3)

	Pm	Dm	bm	tm
63B5	140	11	4	12.8
71B5	160	14	5	16.3
71B14	105			
80B5	200			
80B14	120	19	6	21.8
90B5	200			
90B14	140	24	8	27.3

075 Dimensions

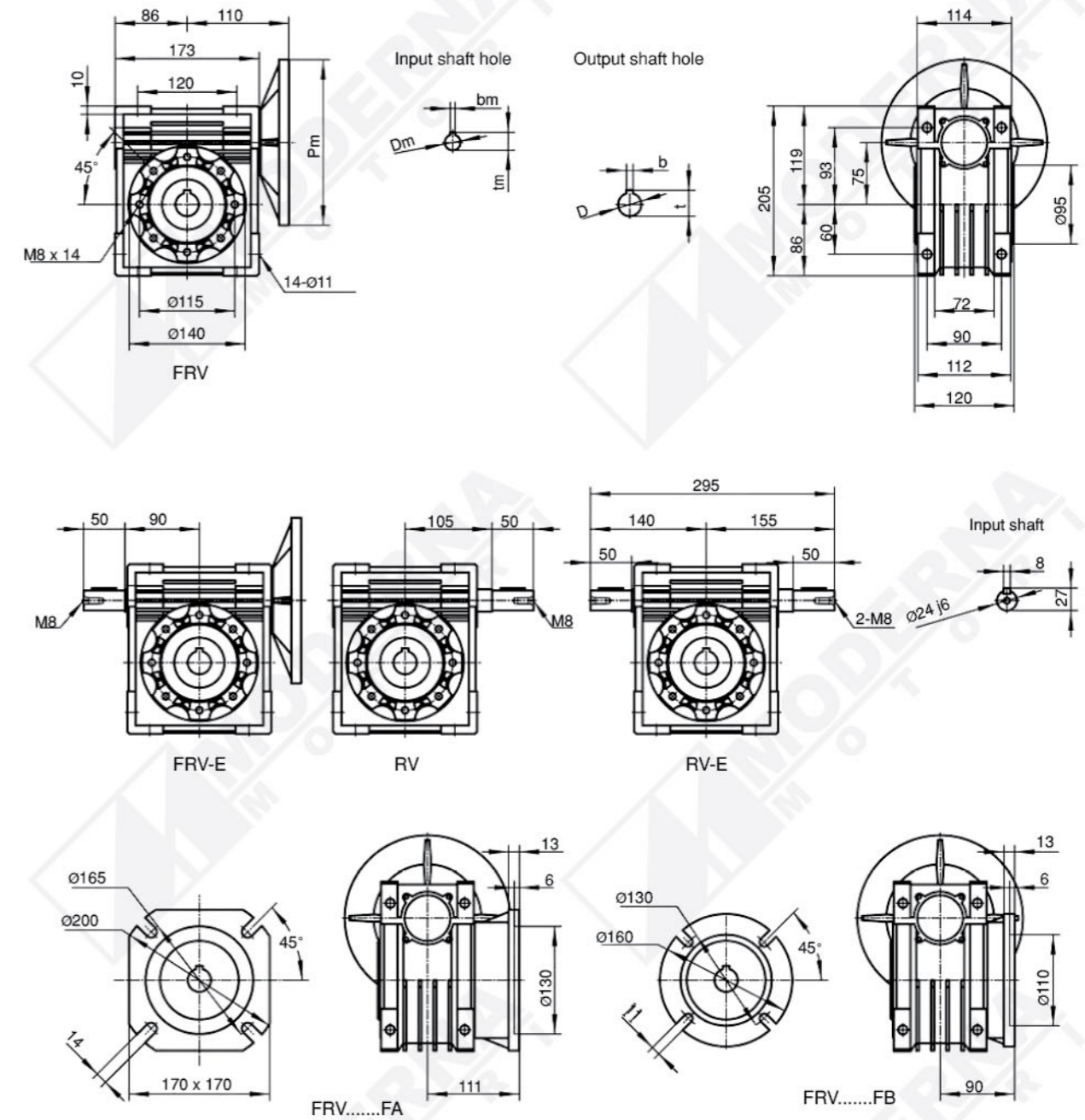

Approx Weight 9 kg

Dimensions of output shaft		
DH7	b D10	t
28	8	31.3
(35)	(10)	(38.3)

	Pm	Dm	bm	tm
71B5	160	14	5	16.3
80B5	200	19	6	21.8
80B14	120			
90B5	200			
90B14	140	24	8	27.3
100/112B5	250			
100/112B14	160	28	8	31.3

090 Dimensions

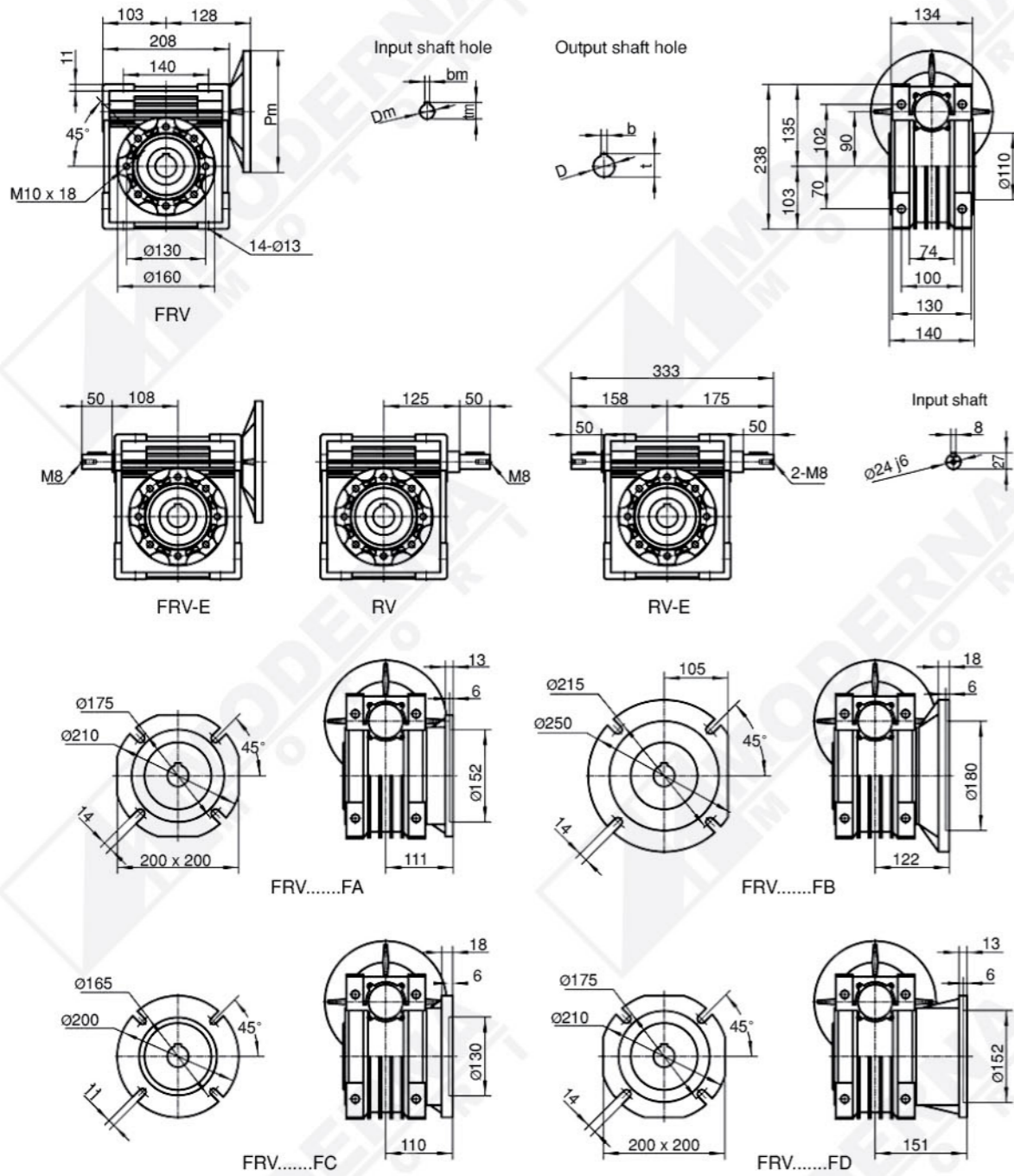

Approx Weight 13 kg

Dimensions of output shaft		
D H7	b D10	t
35	10	38.3
(38)	(10)	(41.3)

	Pm	Dm	bm	tm
80B5	200	19	6	21.8
80B14	120			
90B5	200	24	8	27.3
90B14	140			
100/112B5	250	28	8	31.3
100/112B14	160			

110 Dimensions

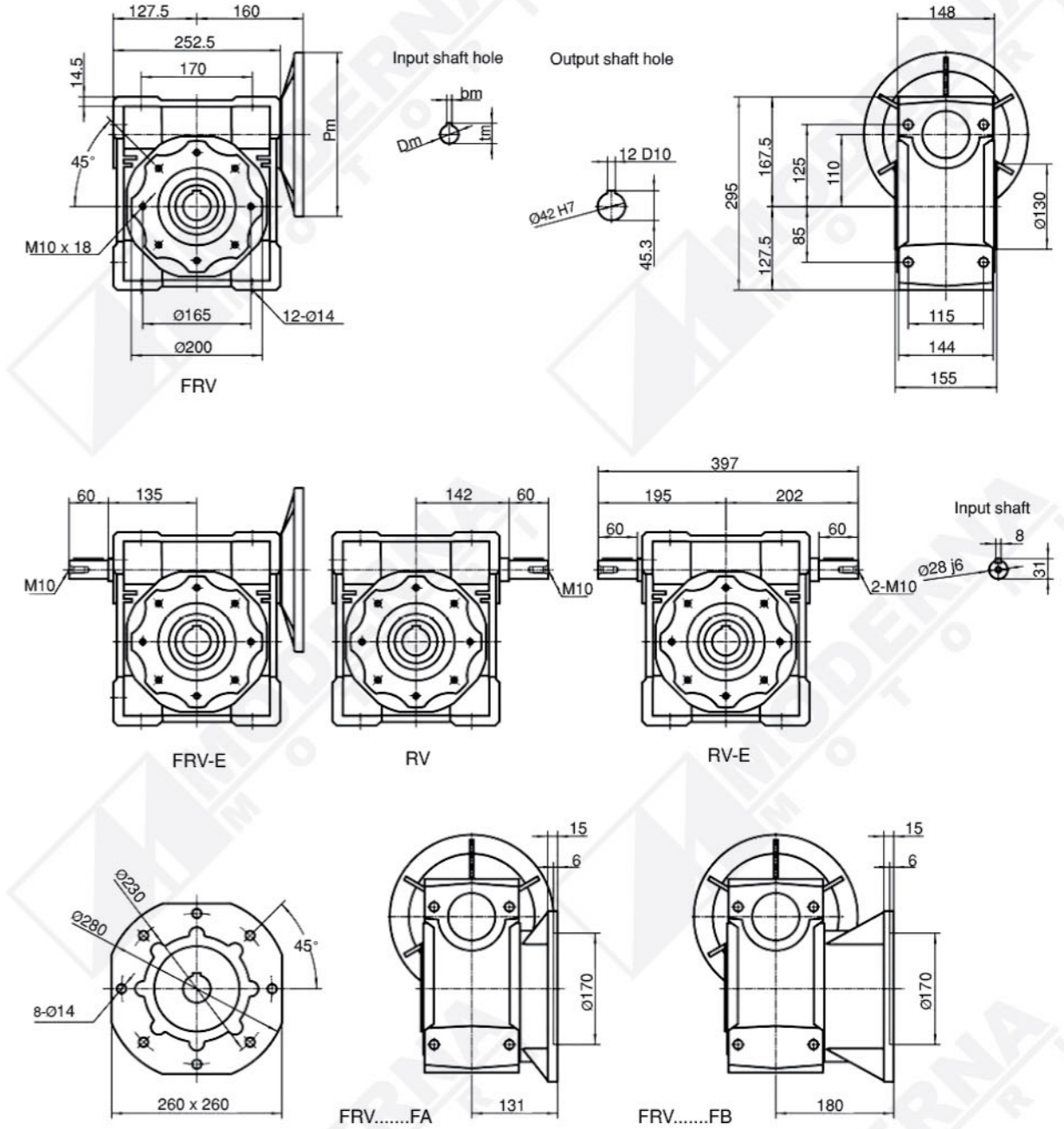

Approx Weight 35 kg

	Pm	Dm	bm	tm
80B5	200	19	6	21.8
90B5	200	24	8	27.3
90B14	140			
100/112B5	250	28	8	31.3
100/112B14	160			
132B5	300	38	10	41.3
132B14	200			

130 Dimensions

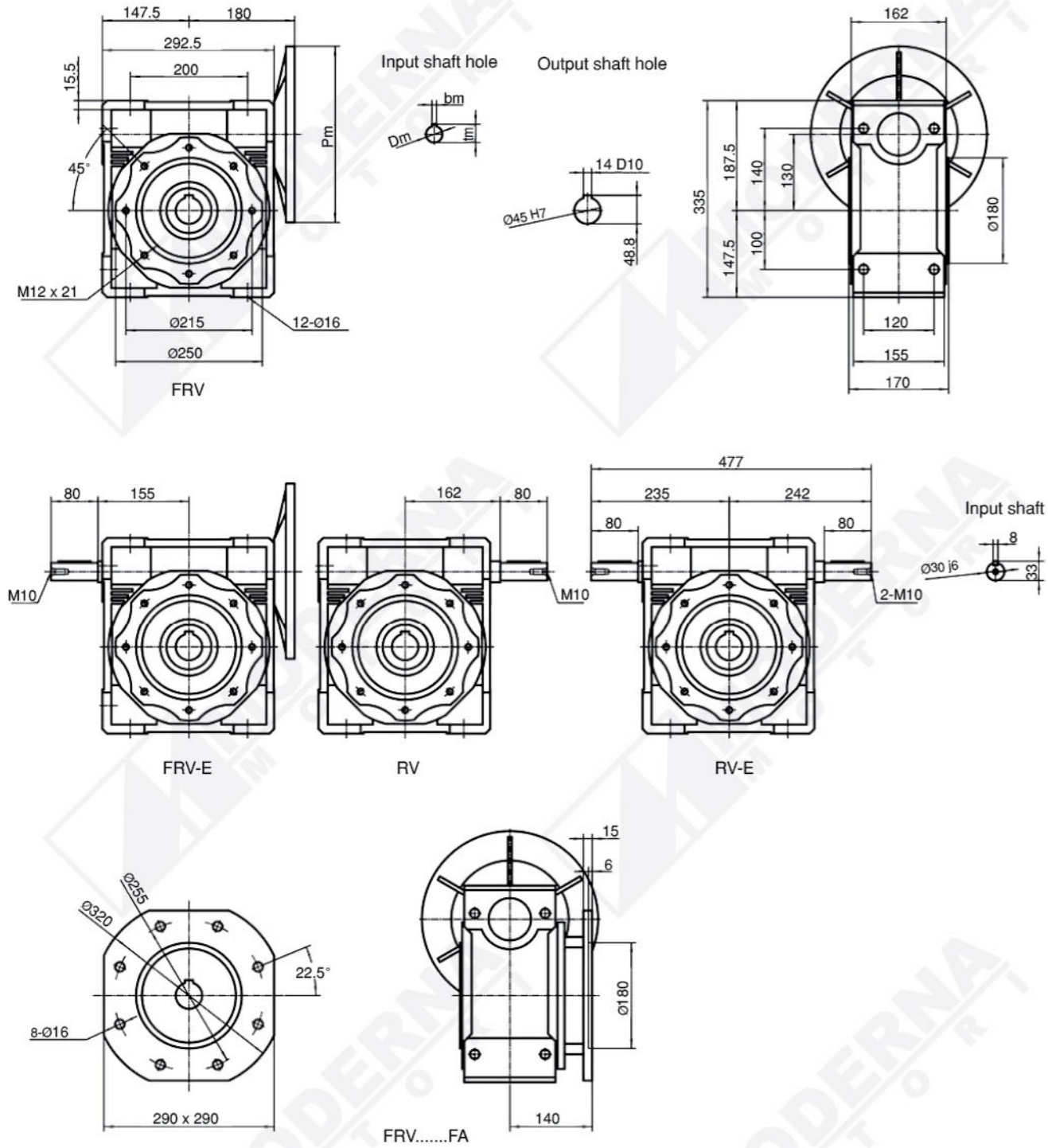

Approx Weight 48 kg

	Pm	Dm	bm	tm
90B5	200	24	8	27.3
90B14	140			
100/112B5	250	28	8	31.3
100/112B14	160			
132B5	300	38	10	41.3
132B14	200			

150 Dimensions

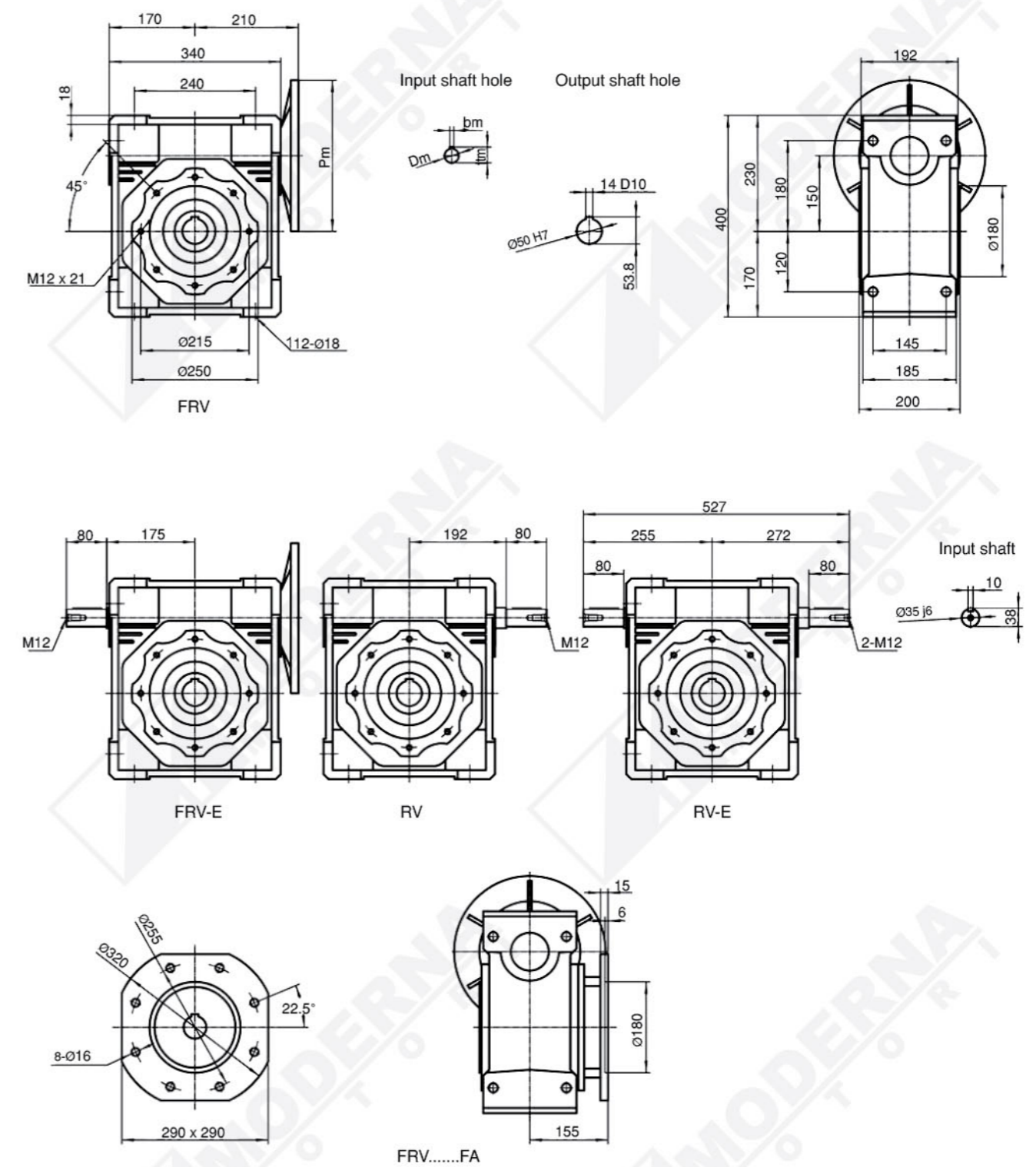

Approx Weight 84 kg

	Pm	Dm	bm	tm
100/112B5	250	28	8	31.3
132B5	300	38	10	41.3
160B5	350	42	12	45.3

PC - FRV Dimensions

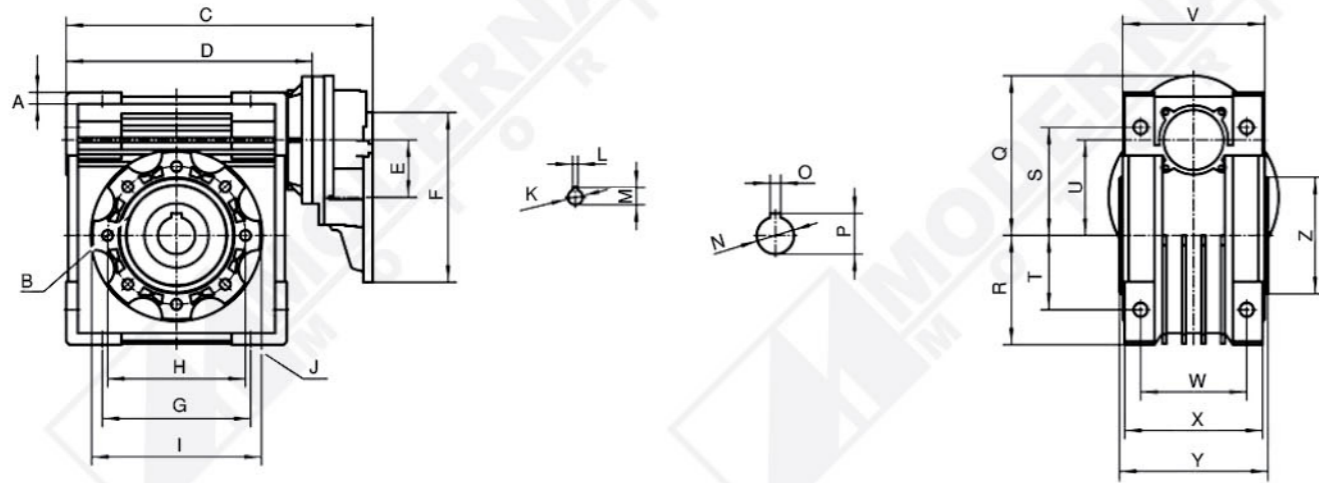

	PC63-040	PC63-050	PC63-063	PC71-050	PC71-063	PC71-075	PC71-090	PC80-075	PC80-090	PC80-110	PC80-130	PC90-110	PC90-130
A	6.5	7	8	7	8	10	11	10	11	14.5	15.5	14.5	15.5
B	4-M6x8	4-M8x10	8-M8x14	4-M8x10	4-M8x14	8-M8x14	8-M10x18	8-M8x14	8-M10x18	8-M10x18	8-M12x21	8-M10x18	8-M12x21
C	167	187	214	197	224	253	288	270	305	361.5	401.5	361.5	401.5
D	120	140	167	140	167	196	231	196	231	287.5	327.5	287.5	327.5
E	43	43	43	54	54	54	54	66	66	66	66	66	66
F	ø140	ø140	ø140	ø160	ø160	ø160	ø160	ø200	ø200	ø200	ø200	ø200	ø200
G	70	80	100	80	100	120	140	120	140	170	200	170	200
H	ø75	ø85	ø95	ø115	ø130	ø115	ø130	ø115	ø130	ø160	ø215	ø160	ø215
I	ø87	ø100	ø110	ø100	ø110	ø140	ø160	ø140	ø160	ø200	ø250	ø200	ø250
J	14-ø6.5	14-ø8.5	14-ø9	14-ø8.5	14-ø9	14-ø11	14-ø13	14-ø11	14-ø13	12-ø14	12-ø16	12-ø14	12-ø16
K	ø11	ø11	ø11	ø14	ø14	ø14	ø14	ø19	ø19	ø19	ø19	ø24	ø24
L	4	4	4	5	5	5	5	6	6	6	6	8	8
M	12.8	12.8	12.8	16.3	16.3	16.3	16.3	21.8	21.8	21.8	21.8	27.3	27.3
N	ø18	ø25	ø25	ø25	ø25	ø28	ø35	ø28	ø35	ø42	ø45	ø42	ø45
O	6	8	8	8	8	8	10	8	10	12	14	12	14
P	20.8	28.3	28.3	28.3	28.3	31.3	38.3	31.3	38.3	45.3	48.8	45.3	48.8
Q	100	110	123	110.5	123.5	135.5	150.5	155	160	190	210	190	210
R	50	60	72	60	72	86	103	86	103	127.5	147.5	127.5	147.5
S	55	64	80	64	80	93	102	93	102	125	140	125	140
T	35	40	50	40	50	60	70	60	70	85	100	85	100
U	40	50	63	50	63	75	90	75	90	110	130	110	130
V	73	87	106	87	106	114	134	114	134	148	162	148	162
W	60	70	85	70	85	90	100	90	100	115	120	115	120
X	71	85	103	85	103	112	130	112	130	144	155	144	155
Y	78	92	112	92	112	120	140	120	140	155	170	155	170
Z	ø60	ø70	ø80	ø70	ø80	ø95	ø110	ø95	ø110	ø130	ø180	ø130	ø180
kg.	4	5.2	8	5.8	8.5	11.3	15.3	13.1	17.2	39.1	52.2	39.1	52.2

FRV / FRV Dimensions

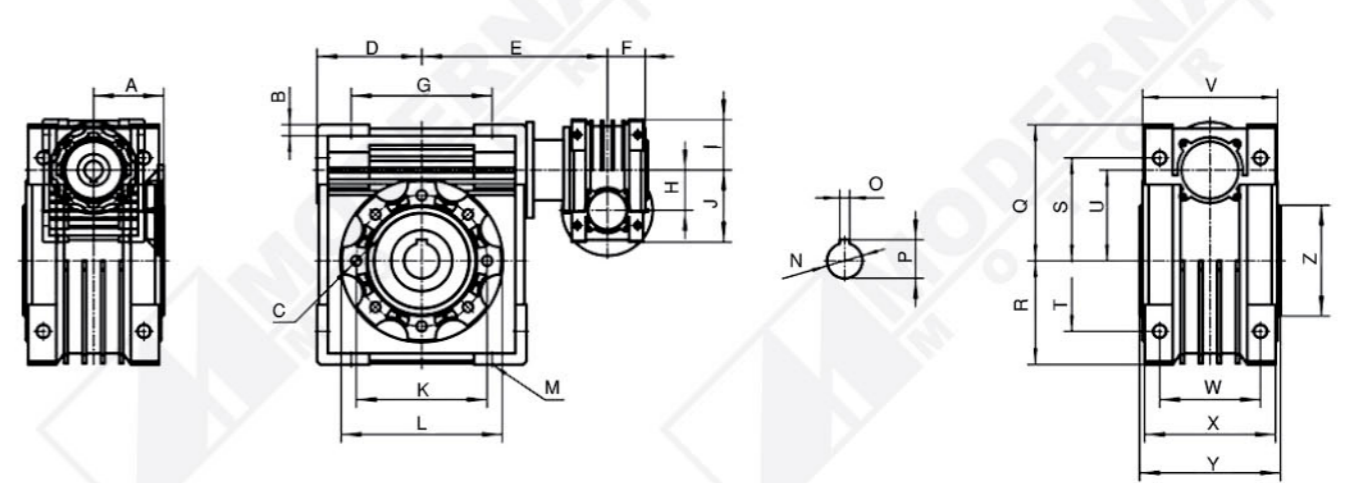

	25/30	25/40	30/40	30/50	30/63	40/75	40/90	50/110	63/130	63/150
A	45	45	55	55	55	70	70	80	95	95
B	6	6.5	6.5	7	8	10	11	14.5	15.5	18
C	4-M6x11	4-M6x8	4-M6x8	4-M8x10	8-M8x14	8-M8x14	8-M10x18	8-M10x18	8-M12x21	8-M12x21
D	40	50	50	50	72	86	103	127.5	147.5	170
E	100	115	120	130	145	163.5	182.5	227.5	245	275
F	22.5	22.5	29	29	29	36.5	36.5	43.5	53	53
G	54	70	70	80	100	120	140	170	200	240
H	25	25	30	30	30	40	40	50	63	63
I	35	35	40	40	40	50	50	60	72	72
J	48	48	57	57	57	71.5	71.5	84	102	102
K	ø65	ø75	ø75	ø85	ø95	ø115	ø130	ø165	ø215	ø215
L	ø75	ø87	ø87	ø100	ø110	ø140	ø160	ø200	ø250	ø250
M	14-ø6.5	14-ø6.5	14-ø6.5	14-ø8.5	14-ø9	14-ø11	14-ø13	12-ø14	12-ø16	12-ø18
N	ø14	ø18	ø18	ø25	ø25	ø28	ø35	ø42	ø45	ø50
O	5	6	6	8	8	8	10	12	14	14
P	16.3	20.8	20.8	28.3	28.3	31.3	38.3	45.3	48.8	53.8
Q	57	71.5	71.5	84	102	119	135	167.5	187.5	230
R	40	50	50	60	72	86	103	127.5	147.5	170
S	44	55	55	64	80	93	102	125	140	180
T	27	35	35	40	50	60	70	85	100	120
U	30	40	40	50	63	75	90	110	130	150
V	58	73	73	87	106	114	134	148	162	192
W	44	60	60	70	85	90	100	115	120	145
X	56	71	7	85	103	112	130	144	155	185
Y	63	78	78	92	112	120	140	155	170	200
Z	ø55	ø60	ø60	ø70	ø80	ø95	ø110	ø130	ø180	ø180
kg.	2.1	3.2	3.9	5	7.8	12	16	39.2	55	91.2

IEC B5 / PAM B5 Dimensions

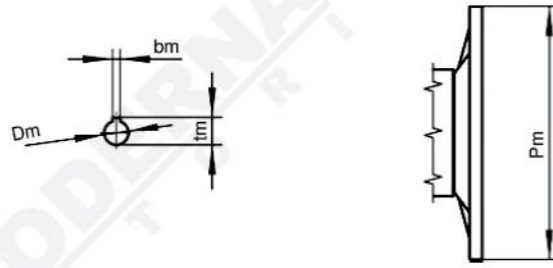

B5	IEC							
	056	063	071	080	090	100/112	132	180
Pm	120	140	160	200	200	250	300	350
Dm	9	11	14	19	24	28	38	42
bm	3	4	5	6	8	8	10	12
tm	10.4	12.8	16.3	21.8	27.3	31.3	41.3	45.3

IEC B14 / PAM B14 Dimensions



B14av	IEC						
	056	063	071	080	090	100/112	132
Pm	80	90	105	120	140	160	200
Dm	9	11	14	19	24	28	38
bm	3	4	5	6	8	8	10
tm	10.4	12.8	16.3	21.8	27.3	31.3	41.3

PAM TFFC C FACE Dimensions

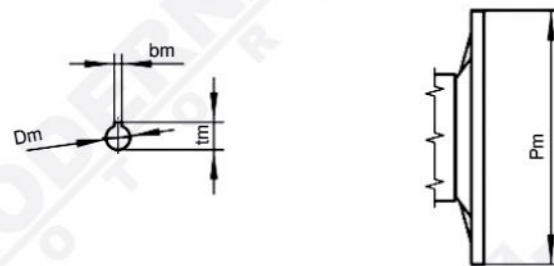

CTC	(Inch)		
	56C	140T	180TC
Pm	6.496	6.496	9
Dm	0.625	0.875	1.125
bm	0.1875	0.1875	0.25
tm	0.709	0.964	1.241

PC Pre-stage helical module Dimensions

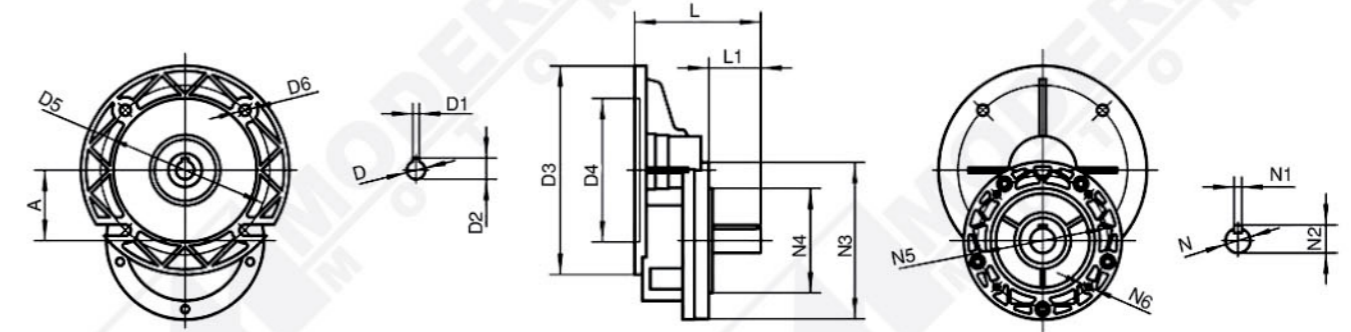

	PC63	PC71	PC80	PC90	PC56C(inch)
A	43	54	66	66	2.126
D	11	14	19	24	0.625
D1	4	5	6	8	0.1875
D2	12.8	16.3	21.8	27.3	0.709
D3	140	160	200	200	6.5
D4	95	110	130	130	4.5
D5	115	130	165	165	5.875
D6	8.5	8.5	11	11	0.415
N	14	19	28	28	0.748
N1	5	6	8	8	0.236
N2	16	21.5	31	31	0.846
N3	105	120	160	160	4.724
N4	70	80	110	110	3.150
N5	85	100	130	130	3.937
N6	M6	M6	M8	M8	M6
L	77	80	134	134	5.787
L1	30	40	60	60	1.575
kg.	1.7	2.3	4.1	4.1	-

Torque arm Dimensions

25

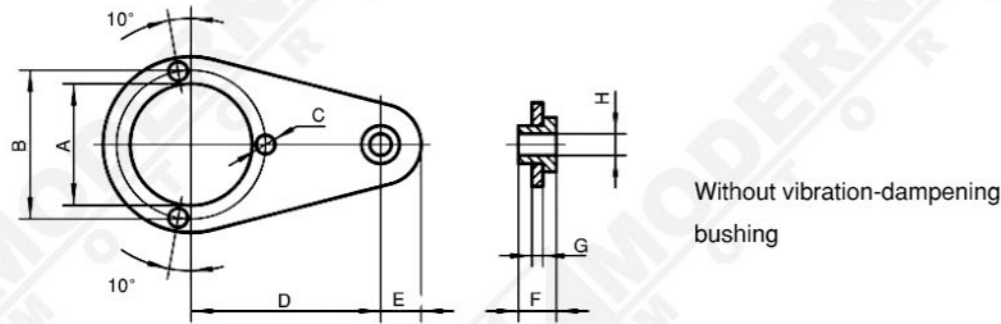

030 ÷ 150

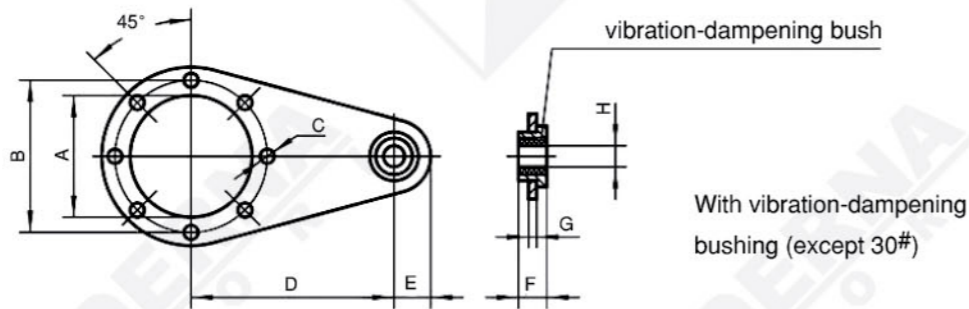

	A	B	C	D	E	F	G	H
025	45	55	7	70	15	14	4	8
030	55	65	7	85	15	14	4	8
040	60	75	7	100	18	14	4	10
050	70	85	9	100	18	14	4	10
063	80	95	9	150	20	14	6	10
075	95	115	9	200	30	25	6	20
090	110	130	11	200	30	25	6	20
110	130	165	11	250	35	30	6	25
130	180	215	13	250	35	30	6	25
150	180	215	13	250	35	30	6	25

Output flange Dimensions

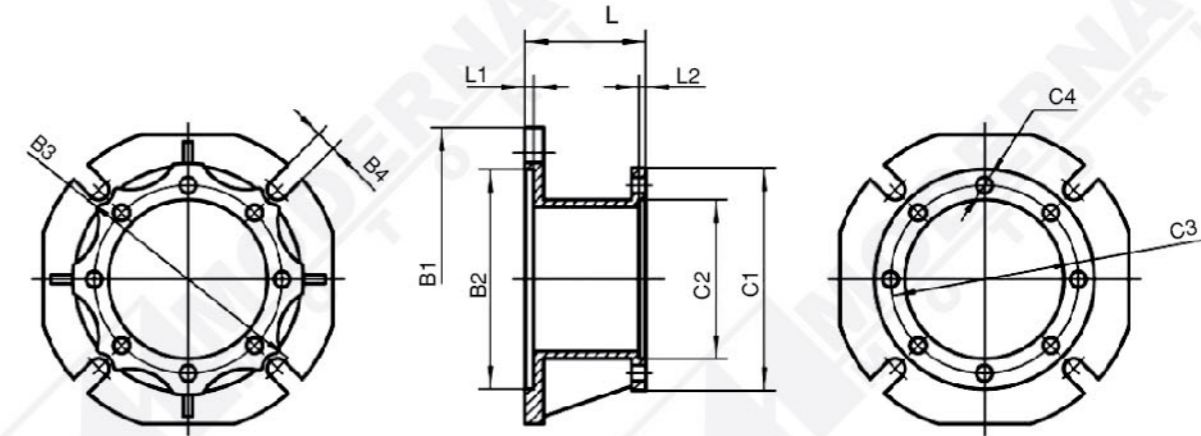

	FA										
	B1	B2	B3	B4	L	L1	L2	C1	C2	C3	C4
025	75	40	55	4-ø 6.5	22.5	3	3	70	45	55	3-M6
030	80	50	68	4-ø 6.5	25.5	4	3	75	55	65	4-ø 7
040	110	60	75	4-ø 9	30.5	4	3.5	87	60	75	4-ø 7
050	125	70	85	4-ø 11	46.5	5	4	100	70	85	4-ø 9
063	180	115	150	4-ø 11	29	6	/	110	80	95	8-ø 9
075	200	130	165	4-ø 14	54	6	/	140	95	115	8-ø 9
090	210	152	175	4-ø 14	44	6	/	160	110	130	8-ø 11
110	280	170	230	8-ø 14	57	6	/	200	130	165	8-ø 11
130	320	180	255	8-ø 16	59	6	5	250	160	215	8-ø 14
150	320	180	255	8-ø 16	59	6	5	250	160	215	8-ø 14

	FB										
	B1	B2	B3	B4	L	L1	L2	C1	C2	C3	C4
040	110	60	75	4-ø 9	60.5	4	3.5	87	60	75	4-ø 7
050	125	70	85	4-ø 11	76.5	5	4	100	70	85	4-ø 9
063	180	115	150	4-ø 11	59	6	/	110	80	95	8-ø 9
075	160	110	130	4-ø 11	33	6	/	140	95	115	4-ø 9
090	250	180	215	4-ø 14	55	6	/	160	110	130	8-ø 11
110	280	170	230	8-ø 14	106	6	/	200	130	165	8-ø 11

	FC										
	B1	B2	B3	B4	L	L1	L2	C1	C2	C3	C4
040	140	95	115	4-ø 9.5	43.5	5	/	87	60	75	4-ø 7
050	160	110	130	4-ø 11	43.5	5	/	100	70	85	4-ø 9
063	200	130	165	4-ø 11	45	5	/	110	80	95	8-ø 9
090	200	130	165	4-ø 11	43	6	/	160	110	130	8-ø 11

	FD										
	B1	B2	B3	B4	L	L1	L2	C1	C2	C3	C4
040	120	80	100	4-ø 9	22	5	/	87	60	75	4-ø 7
050	140	95	115	4-ø 11	28.5	5	/	100	70	85	4-ø 9
063	200	130	165	4-ø 11	54	5	/	110	80	95	8-ø 9
090	210	152	175	4-ø 14	84	6	/	160	110	130	8-ø 11

Output shafts Dimensions

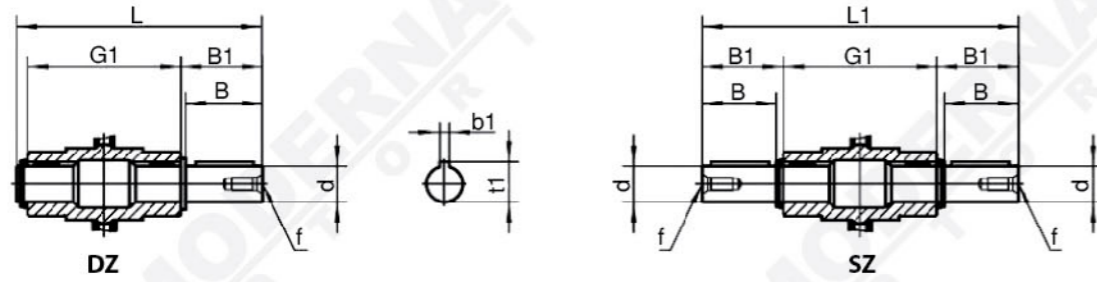

	d	B	B1	G1	L	L1	f	b1	t1
025	11	23	25.5	50	81	101	/	4	12.5
030	14	30	32.5	63	102	128	M6	5	16
040	18	40	43	78	128	164	M6	6	20.5
050	25	50	53.5	92	153	199	M10	8	28
063	25	50	53.5	112	173	219	M10	8	28
075	28	60	63.4	120	192	247	M10	8	31
090	35	80	84.5	140	234	309	M12	10	38
110	42	80	84.5	155	249	324	M16	12	45
130	45	80	85	170	265	340	M16	14	48.5
150	50	82	87	200	297	374	M16	14	53.5

Double stage coupling flange Dimensions

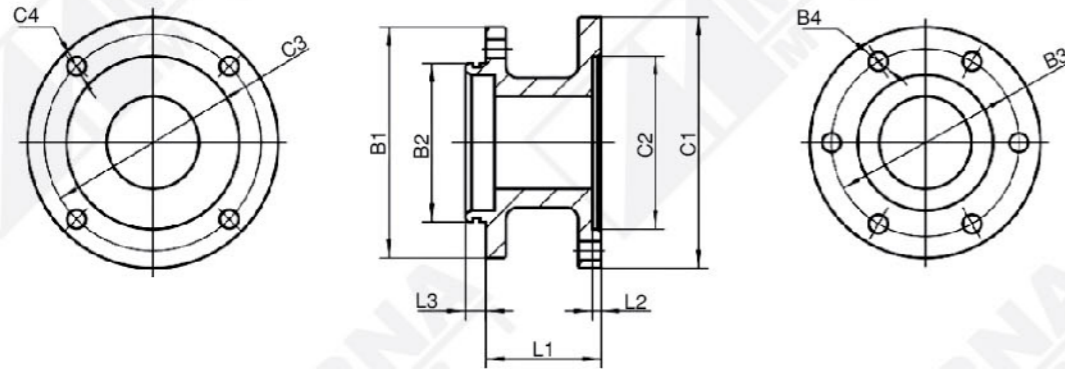

	B1	B2	B3	B4	L1	L2	L3	C1	C2	C3	C4
025/030	58	37	45	4-ø 5.5	36.5	3	6	70	45	55	3-ø 7
025/040	75	47	57	6-ø 6.8	41.5	3	6.8	70	45	55	3-ø 7
030/040	75	47	57	6-ø 6.8	40	3.5	6.8	75	55	65	4-ø 6.8
030/050	80	55	65	6-ø 6.8	40	3.5	7	75	55	65	4-ø 6.8
030/063	89	62	75	6-ø 9	42	3.5	7	75	55	65	4-ø 7
040/075	96	68	82	6-ø 9	41	3.5	7	87	60	75	4-ø 7
040/090	96	68	82	6-ø 9	41	3.5	7	87	60	75	4-ø 7
050/110	115	80	95	6-ø 9	56.5	3.5	7	100	70	85	4-ø 9
063/130	115	80	95	6-ø 9	47	4	7	110	80	95	8-ø 9
063/150	155	110	130	6-ø 13	52	4	10	110	80	95	8-ø 9

Double stage coupling shaft

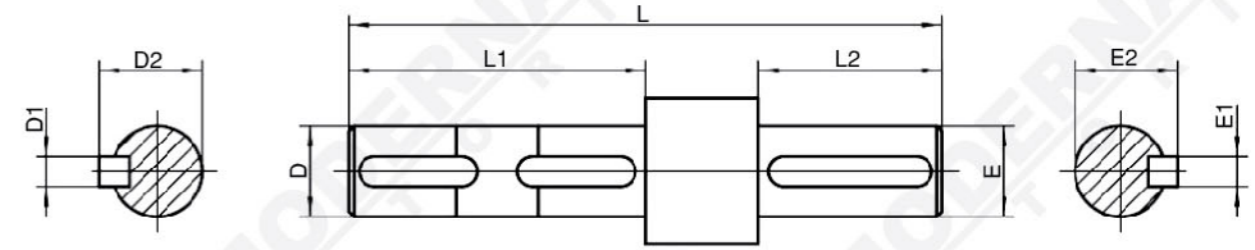

	D	D1	D2	L	L1	L2	E	E1	E2
040/075	18	6	20.5	145	70	52.5	28	8	31
040/090	18	6	20.5	145	70	52.5	28	8	31
050/110	25	8	28	182.5	89	63	38	10	41
063/150	25	8	28	193 213	105	70 90	38 42	10 12	41 45

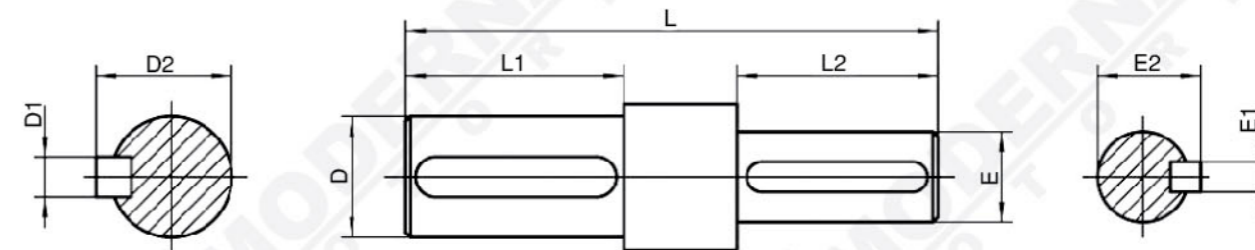

	D	D1	D2	L	L1	L2	E	E1	E2
025/030	11	4	12.5	71.5 73.5	32	16	9	3	10.2
025/040	11	4	12.5	75.5 82	32	18	11	4	12.5
030/040	14	5	16	84.5	35.5	25	14	5	16
030/050	14	5	16	76.5 82.5 86.5 92.5	35.5	18 24 24	11 14 14	4 5 5	12.5 16 16
030/063	14	5	16	96.5 98	35.5	34 35.5	19 24	6 8	21.5 27
040/075	18	6	20.5	96 106	40	33.5 43.5	19 24	6 8	21.5 27
040/090	18	6	20.5	96 106	40	33.5 43.5	19 24	6 8	21.5 27
050/110	25	8	28	124 134	53.5	40 50	24 28	8 8	27 31
063/130	25	8	28	117 127 147	57.5	38 48	24 28	8 8	27 31
063/150	25	8	28	118	50	68 50	38 28	10 8	41 31

Performance parameter of Single FRV series

Input	Size	i	n ₂ (r/min)	M ₂ (Nm)	S.F	
0.06kw 4P n ₁ =1400r/min	25	7.5	186.7	2.6	4.2	
	30	7.5	186.7	2.6	6.9	
	25	10	140	3.4	3.5	
	30	10	140	3.4	5.4	
	25	15	93.3	4.9	2.5	
	30	15	93.3	4.7	3.8	
	25	20	70	6.1	2	
	30	20	70	6	3	
	25	25	56	6.5	1.8	
	30	25	56	7	3	
	25	30	46.7	8.2	1.6	
	30	30	46.7	8	2.5	
	25	40	35	10.2	1.3	
	30	40	35	9.7	1.9	
	25	50	28	11	0.9	
	30	50	28	11.3	1.5	
	40	50	28	12.7	3	
	0.09kw 4P n ₁ =1400r/min	25	60	23.3	11	0.7
30		60	23.3	12.5	1.3	
40		60	23.3	14.2	2.5	
30		80	17.5	12.5	0.9	
40		80	17.5	17	1.9	
40		100	14	19.2	1.5	
25		7.5	186.7	3.9	2.8	
30		7.5	186.7	3.9	4.5	
25		10	140	5.1	2.4	
30		10	140	5	3.6	
25		15	93.3	7.3	1.6	
30		15	93.3	7.1	2.5	
25		20	70	9.2	1.3	
30		20	70	9	2	
25		25	56	9.7	1.2	
30		25	56	10.4	1.9	
0.12kw 4P n ₁ =1400r/min		25	30	46.7	12.3	1.1
		30	30	46.7	12	1.7
	25	40	35	13	1.1	
	30	40	35	14.5	1.2	
	25	50	28	12	0.9	
	30	50	28	16.9	1	
	40	50	28	19	2	
	30	60	23.3	16.9	0.9	
	40	60	23.3	21.4	1.7	
	30	80	17.5	12.5	0.9	
	40	80	17.5	25.5	1.3	
	40	100	14	28.9	1	
	30	7.5	186.7	5.2	3.4	
	40	7.5	186.7	5.3	7.5	
	30	10	140	6.7	2.7	
	40	10	140	7	5.7	
	30	15	93.3	9.5	1.9	
	40	15	93.3	10.1	3.9	
30	20	70	12	1.5		
0.12kw 4P n ₁ =1400r/min	40	20	70	12.8	3	
	30	25	56	13.9	1.5	
	40	25	56	15.3	2.5	
	30	30	46.7	16	1.3	
	40	30	46.7	17.2	2.6	
	30	40	35	17	1	
	40	40	35	21.3	1.9	
	50	40	35	21.9	3.4	
	40	50	28	25.4	1.5	
	50	50	28	25.8	2.8	
	40	60	23.3	28.5	1.3	

Input	Size	i	n ₂ (r/min)	M ₂ (Nm)	S.F
0.12kw 4P n ₁ =1400r/min	50	60	23.3	29	2.3
	40	80	17.5	34.1	1
	50	80	17.5	34.7	1.9
	40	100	14	38	0.8
	50	100	14	40.1	1.4
	0.18kw 4P n ₁ =1400r/min	30	7.5	186.7	8
40		7.5	186.7	8	5
30		10	140	10	1.8
40		10	140	10	4
30		15	93.3	14	1.3
40		15	93.3	15	2.7
30		20	70	18	1
40		20	70	19	2
30		25	56	20	0.9
40		25	56	23	1.7
40		30	46.7	26	1.7
50		40	35	32	2.3
40		40	35	32	1.3
40		50	28	38	1
50		50	28	38	1.9
40		60	23.3	42	0.8
50		60	23.3	44	1.6
50		80	17.5	53	1.2
50	100	14	59	0.9	
0.25kw 4P n ₁ =1400r/min	40	7.5	186.7	11	3.6
	50	7.5	186.7	11	6.5
	40	10	140	14	2.8
	50	10	140	14	5.1
	40	15	93.3	20	1.9
	50	15	93.3	21	3.5
	40	20	70	26	1.5
	50	20	70	26	2.7
	40	25	56	31	1.2
	50	25	56	32	2.2
	40	30	46.7	36	1.3
	50	30	46.7	36	2.3
	40	40	35	44	0.9
	50	40	35	45	1.7
	50	50	28	53	1.4
	50	60	23.3	60	1.1
	50	80	17.5	72	0.9
	63	80	17.5	77	1.6
63	100	14	87	1.4	
0.37kw 4P n ₁ =1400r/min	40	7.5	186.7	16	2.4
	50	7.5	186.7	16	4.4
	40	10	140	21	1.9
	50	10	140	21	3.3
	40	15	93.3	30	1.3
	50	15	93.3	31	2.4
	40	20	70	39	1
	50	20	70	39	1.8
	40	25	56	56	0.8
	50	25	56	47	1.5
	50	30	46.7	54	1.5
	50	40	35	66	1.1
	63	40	35	70	2.1
	50	50	28	80	0.9
	63	50	28	83	1.6
	50	60	23.3	89	0.8
	63	60	23.3	95	1.4
	63	80	17.5	114	1.1
63	100	14	129	0.9	

Performance parameter of Single FRV series

input	Size	i	n ₂ (r/min)	M ₂ (Nm)	S.F
0.55kw 4P n ₁ =1400r/min	40	7.5	186.7	24.5	1.6
	50	7.5	186.7	25	2.9
	40	10	140	32	1.25
	50	10	140	32	2.2
	50	15	93.3	46	1.6
	63	15	93.3	46	3
	50	20	70	59	1.2
	63	20	70	60	2.2
	50	25	56	70	1
	63	25	56	72	1.8
	63	30	46.7	82	1.9
	63	40	35	104	1.4
	75	40	35	108	2
	63	50	28	123	1.1
	75	50	28	129	1.6
	63	60	23.3	140	0.9
	75	60	23.3	146	1.4
	75	80	17.5	180	1.1
75	100	14	206	0.9	
0.75kw 4P n ₁ =1400r/min	50	7.5	186.7	34	2.1
	63	7.5	186.7	33	3.9
	50	10	140	44	1.6
	63	10	140	44	2.9
	50	15	93.3	63	1.2
	63	15	93.3	63	2.2
	50	20	56	80	0.9
	63	20	70	82	1.6
	63	25	56	99	1.3
	63	30	46.7	112	1.4
	75	30	46.7	116	2
	63	40	35	143	1
	75	40	35	147	1.5
	63	50	28	168	0.8
	75	50	28	176	1.2
	90	50	28	184	1.8
	75	60	23.3	200	1
	90	60	23.3	212	1.5
75	80	17.5	245	0.8	
90	80	17.5	257	1.1	
90	100	14	302	0.9	
1.1kw 4P n ₁ =1400r/min	63	7.5	186.7	49	2.6
	75	7.5	186.7	49	3.8
	63	10	140	65	2
	75	10	140	66	2.9
	63	15	93.3	93	1.5
	75	15	93.3	95	2.1
	63	20	70	120	1.1
	75	20	70	122	1.7
	75	25	56	149	1.3
	75	30	46.7	170	1.3
	75	40	35	216	1
	90	40	35	225	1.6
	90	50	28	271	1.3
	90	60	23.3	311	1
	110	60	23.3	324	1.9
	110	80	17.5	410	1.3
	110	100	14	473	1
	1.5kw 4P n ₁ =1400r/min	63	7.5	186.7	68
75		7.5	186.7	67	2.8
63		10	140	88	1.5
75		10	140	90	2.2
63		15	93.3	126	1.1
75		15	93.3	130	1.5
63		20	70	164	0.8
75		20	70	167	1.3
75		25	56	200	1
90		25	56	209	1.6
75		30	46.7	230	1
90		30	46.7	236	1.7
90		40	35	306	1.2
90		50	28	369	0.9
110		50	28	375	1.7
110		60	23.3	442	1.4
110		80	17.5	548	0.9
130		80	17.5	557	1.5
130	100	14	652	1.1	
2.2kw 4P n ₁ =1400r/min	75	7.5	186.7	99	1.8
	90	7.5	186.7	101	2.9
	75	10	140	131	1.5
	90	10	140	133	2.3
	75	15	93.3	189	1

input	Size	i	n ₂ (r/min)	M ₂ (Nm)	S.F
2.2kw 4P n ₁ =1400r/min	90	15	93.3	193	1.9
	110	15	93.3	193	3.4
	90	20	70	251	1.4
	110	20	70	256	2.5
	90	25	56	307	1.1
	110	25	56	316	2.2
	90	30	46.7	351	1.2
	110	30	46.7	355	2
	110	40	35	462	1.5
	110	50	28	550	1.2
	130	50	28	566	1.7
	150	50	28	570	2.5
	130	60	23.3	650	1.4
	150	60	23.3	657	1.9
	130	80	17.5	816	1
	150	80	17.5	816	1.4
	150	100	14	960	1
	3kw 4P n ₁ =1400r/min	75	7.5	186.7	135
90		7.5	186.7	137	2.1
110		7.5	186.7	138	4
75		10	140	178	1.1
110		10	140	182	3.3
75		15	93.3	258	0.8
90		15	93.3	261	1.4
110		15	93.3	263	2.5
90		20	70	340	1
110		20	70	348	1.9
90		25	56	414	0.8
110		25	56	430	1.6
90		30	46.7	479	0.9
110		30	46.7	484	1.5
110		40	35	631	1.1
130		40	35	638	1.6
110		50	28	757	0.9
130		50	28	767	1.3
150	50	28	778	1.8	
130	60	23.3	884	1	
150	60	23.3	896	1.4	
130	80	17.5	1097	0.8	
150	80	17.5	1110	1	
90	7.5	186.7	182	1.6	
110	7.5	186.7	184	0.8	
130	7.5	186.7	186	4	
90	10	140	240	1.3	
110	10	140	243	2.5	
130	10	140	243	3.4	
90	15	93.3	348	1.0	
110	15	93.3	352	1.9	
130	15	93.3	357	2.6	
110	20	70	464	1.4	
130	20	70	466	1.9	
110	25	56	573	1.2	
130	25	56	573	1.6	
110	30	46.7	646	1.1	
130	30	46.7	655	1.6	
110	40				

Performance parameter of Double FRV/FRV (worm-worm) Series ($n_1=1,400$ r/min)

Size	l	n_2 (r/min)	kW_1	M_2 (N·m)	i_1	i_2	S.F
30/40	100	14	0.09	40	10	10	1.8
	150	9.3	0.09	54	7.5	20	1.3
	200	7.0	0.09	58	10	20	1.1
	250	5.6	0.06	52	10	25	1.2
	300	4.7	0.06	70	10	30	1.2
	400	3.5	0.05	63	10	40	1
	500	2.8	0.04	57	20	25	1
	600	2.3	0.04	72	20	30	1
	750	1.9	0.04	72	25	30	1
	900	1.6	0.03	73	30	30	1
	1200	1.2	0.03	73	30	40	1
	1500	0.9	0.02	73	50	30	1
	1800	0.8	0.02	73	60	30	1
	2400	0.6	0.01	65	60	40	1
	3200	0.4	0.01	65	80	40	1
	30/50	100	14	0.18	80	10	10
150		9.3	0.18	110	7.5	20	1.2
200		7.0	0.12	92	10	20	1.2
250		5.6	0.12	110	10	25	1
300		4.7	0.14	142	10	30	1
400		3.5	0.10	127	10	40	1
500		2.8	0.08	123	10	50	1
600		2.3	0.08	143	20	30	1
750		1.9	0.07	148	25	30	1
900		1.6	0.06	141	30	30	1
1200		1.2	0.05	145	30	40	1
1500		0.9	0.04	145	50	30	1
1800		0.8	0.04	145	60	30	1
2400		0.6	0.03	124	60	40	1
3000		0.5	0.02	120	60	50	1
30/63		100	14	0.18	80	10	10
	150	9.3	0.18	112	7.5	20	1.9
	200	7.0	0.18	142	10	20	1.8
	250	5.6	0.18	173	10	25	1.3
	300	4.7	0.22	210	7.5	40	1.2
	400	3.5	0.18	222	10	40	1.1
	500	2.8	0.18	260	10	50	0.9
	600	2.3	0.12	217	15	40	1.2
	750	1.9	0.12	250	15	50	1.1
	900	1.6	0.09	210	15	60	1.3
	1200	1.2	0.09	270	30	40	1
	1500	0.9	0.06	204	30	50	1.3
	1800	0.8	0.06	230	30	60	1.2
	2400	0.6	0.06	300	60	40	0.8
	3000	0.5	0.06	333	60	50	0.7
	40/63	100	14	0.37	170	10	10
150		9.3	0.37	240	7.5	20	1.1
200		7.0	0.25	204	10	20	1.2
250		5.6	0.25	231	10	25	1
300		4.7	0.25	271	10	30	1
400		3.5	0.25	319	10	40	0.8
500		2.8	0.12	213	10	50	1.1
600		2.3	0.12	232	15	40	1.2
750		1.9	0.12	295	25	30	0.9
900		1.6	0.09	243	30	30	1.1
1200		1.2	0.09	305	30	40	0.9
1500		0.9	0.06	232	50	30	1.2
1800		0.8	0.06	271	60	30	1
2400		0.6	0.06	306	60	40	0.8
3000		0.5	0.06	354	60	50	0.7
40/75		100	14	0.37	171	10	10
	150	9.3	0.37	245	7.5	20	1.7
	200	7.0	0.37	311	10	20	1.3
	250	5.6	0.37	380	10	25	1
	300	4.7	0.37	405	10	30	1.1
	400	3.5	0.25	336	10	40	1.2
	500	2.8	0.25	368	10	50	1
	600	2.3	0.18	380	20	30	1.2
	750	1.9	0.18	440	25	30	1
	900	1.6	0.12	325	30	30	1.3
	1200	1.2	0.12	400	30	40	1.1
	1500	0.9	0.09	360	50	30	1.2
	1800	0.8	0.09	404	60	30	1.1
	2400	0.6	0.06	350	60	40	1.2
	3000	0.5	0.06	360	60	50	1
	40/90	100	14	0.37	176	10	10
150		9.3	0.37	251	7.5	20	2.1
200		7.0	0.37	322	10	20	1.9
250		5.6	0.37	383	10	25	1.9
300		4.7	0.37	430	7.5	40	1.6
400		3.5	0.37	535	10	40	1.1
500		2.8	0.37	625	10	50	0.9
600		2.3	0.37	770	15	40	0.9
750		1.9	0.25	640	15	50	1.1
900		1.6	0.25	700	15	60	1
1200		1.2	0.18	629	30	40	1.1
1500		0.9	0.18	770	30	50	0.9
1800		0.8	0.12	600	30	60	1.2
2400		0.6	0.12	760	60	40	0.8
3000		0.5	0.09	630	60	50	0.9
50/90		100	14	0.75	366	10	10
	150	9.3	0.75	521	7.5	20	1.3
	200	7.0	0.75	663	10	20	0.9
	250	5.6	0.55	570	10	25	1
	300	4.7	0.55	653	10	30	1.1
	400	3.5	0.37	550	10	40	1.1
	500	2.8	0.37	727	10	50	0.8
	600	2.3	0.37	809	15	40	0.9
	750	1.9	0.25	648	25	30	1.1
	900	1.6	0.25	761	30	30	0.9
	1200	1.2	0.18	663	30	40	1.1
	1500	0.9	0.18	787	50	30	0.9
	1800	0.8	0.18	900	60	30	0.8
	2400	0.6	0.12	732	60	40	0.8
	3000	0.5	0.09	630	60	50	0.9
	50/110	100	14	0.75	365	10	10
150		9.3	0.75	528	7.5	20	1.8
200		7.0	0.75	683	10	20	1.7
250		5.6	0.75	838	10	23	1.4
300		4.7	0.75	890	10	30	1.41
400		3.5	0.75	1150	10	40	1
500		2.8	0.55	1130	10	50	1
600		2.3	0.55	1200	15	40	1
750		1.9	0.55	1405	25	30	0.9
900		1.6	0.37	1150	30	30	1.1
1200		1.2	0.25	943	30	40	1.4
1500		0.9	0.25	1064	50	30	1.2
1800		0.8	0.25	1216	60	30	1
2400		0.6	0.18	1001	60	40	1.1
3000		0.5	0.12	916	60	50	1.2
63/130		100	14	1.5	740	10	10
	150	9.3	1.5	1042	7.5	20	1.5
	200	7.0	1.5	1371	10	20	1.2
	250	5.6	1.5	1675	10	25	0.9
	300	4.7	1.50	1789	10	30	1
	400	3.5	1.00	1519	10	40	1.1
	500	2.8	1.00	1629	10	50	0.8
	600	2.3	0.75	1714	15	40	1
	750	1.9	0.75	2060	25	30	0.8
	900	1.6	0.75	2360	30	30	0.7
	1200	1.2	0.55	2150	30	40	0.8
	1500	0.9	0.37	1710	50	30	1
	1800	0.8	0.37	1698	60	30	0.9
	2400	0.6	0.25	1624	60	40	1
	3000	0.5	0.25	1935	60	50	0.8
	63/150	100	14	1.5	1053	7.5	20
200		7	1.5	1371	10	20	1.5
250		5.6	1.5	1671	10	25	1.2
300		4.7	1.5	1980	10	30	1.2
400		3.5	1.5	2350	10	40	1.1
500		2.8	1.1	2010	20	25	1.1
600		2.3	1.1	2480	20	30	1.1
750		1.9	0.75	2001	25	30	1.2
900		1.6	0.75	2540	30	30	0.8
1200		1.2	0.75	2980	30	40	0.9
1500		0.9	0.75	3566	50	30	0.6
1800		0.8	0.37	2080	60	30	1
2400		0.6	0.37	2502	60	40	1
3000		0.5	0.25	2008	60	50	1.2

Performance parameter of Double FRV / PC (worm-gear) series ($n_1=1,400$ r/min)

Size	Ratio	Input Power	Output		
			n_2 (r/min)	M_2 (N·m)	
40/63	75(3x25)	0.12	18.7	42	
		0.18		49	
	90(3x30)	0.12	15.6	45	
		0.18		61	
	120(3x40)	0.12	11.7	50	
		0.18		52	
		150(3x50)	9.3		
			7.8	46	
	180(3x60)	5.8	40		
		4.7	36		
50/63	75(3x25)	0.18	18.7	62	
		0.25	17.7	91	
	90(3x30)	0.18	15.6	69	
		0.25	14.7	102	
	120(3x40)	0.18	11.7	85	
		0.25	11	100	
	150(3x50)	0.12	9.3	66	
		0.18		89	
		180(3x60)	0.12	7.8	74
			0.18	7.8	88
240(3x80)	0.12	5.8	78		
	0.18		76		
63/63	79.3(3.17x25)	0.25	17.7	94	
		0.37	139		
	95.1(3.17x30)	0.25	103		
		0.37	14.7	153	
	126.8(3.17x40)	0.25	11	129	
		0.37	11	191	
	150(3x50)	0.18	9.3	101	
		0.25		148	
	158.5(3.17x50)	0.37	8.8	176	
		0.18	7.8	115	
180(3x60)	0.18	7.8	115		
	0.25	7.4	151		
240(3x80)	0.12	5.8	90		
	0.18		136		
253.6(3.17x80)	0.25	5.5	139		
	0.12		101		
300(3x100)	0.18	4.7	121		
	0.25	4.4	128		
75/71	75(3x25)	0.55		201	
		0.75	18.7	247	
	79.3(3.17x25)	0.37	17.7	143	
		0.55		225	
	90(3x30)	0.75	15.6	307	
		0.92		300	
	95.1(3.17x30)	0.37	14.7	160	
		0.55	11.7	278	
	120(3x40)	0.55	11.7	278	
		0.37	11	198	
126.8(3.17x40)	0.37	11	198		
	0.55	9.3	260		
150(3x50)	0.55	9.3	260		
	0.25	8.8	156		
158.5(3.17x50)	0.37	8.8	231		
	0.25		231		
75/71	190.2(3.17x60)	0.25	7.4	178	
		0.37		236	
	253.6(3.17x80)	0.25	5.5	208	
		0.25	4.4	214	
	317(3.17x100)	0.55	15.6	235	
		0.75		320	
	120(3x40)	0.55	11.7	291	
		0.75		397	
	150(3x50)	0.55	9.3	347	
		0.75	9.3	426	
180(3x60)	0.55	7.8	390		
	0.75		425		
190.2(3.17x60)	0.37	7.4	278		
	0.55	5.8	374		
240(3x80)	0.37	5.5	332		
	0.37	4.4	345		
253.6(3.17x80)	0.37	5.5			

Performance (n1 = 2800)

M2 (Nm)	i	P1 (kW)	n2 (1/min)	Size	Fr2 (N)	Fr1 (N)	η
12	5	0.79	560.0	RV 030	474	115	0.89
13	7.5	0.58	373.3		542	125	0.88
13	10	0.45	280.0		597	140	0.85
13	15	0.31	186.7		683	140	0.82
12	20	0.23	140.0		752	146	0.76
16	25	0.25	112.0		810	210	0.75
15	30	0.21	93.3		861	210	0.70
14	40	0.16	70.0		948	127	0.64
13	50	0.12	56.0		1021	128	0.64
12	60	0.10	45.7		1085	126	0.59
11	80	0.08	35.0		1194	130	0.50
24	5	1.6	560.0	RV 040	912	200	0.88
27	7.5	1.2	373.3		1044	233	0.88
29	10	1.0	280.0		1149	272	0.85
31	15	0.72	186.7		1315	291	0.84
29	20	0.52	140.0		1447	204	0.82
28	25	0.42	112.0		1559	236	0.78
34	30	0.44	93.3		1657	350	0.76
31	40	0.32	70.0		1824	350	0.71
30	50	0.25	56.0		1964	350	0.68
28	60	0.21	46.7		2087	350	0.65
25	80	0.16	35.0		2298	350	0.57
23	100	0.12	28.0		2475	350	0.56
45	5	2.9	560.0	RV 050	1251	280	0.91
52	7.5	2.3	373.3		1433	324	0.88
54	10	1.8	280.0		1577	378	0.88
57	15	1.3	186.7		1805	399	0.86
53	20	0.95	140.0		1987	417	0.82
51	25	0.75	112.0		2140	482	0.80
64	30	0.82	93.3		2274	490	0.76
59	40	0.59	70.0		2503	490	0.73
53	50	0.45	56.0		2696	490	0.69
50	60	0.37	46.7		2865	490	0.66
45	80	0.27	35.0		3153	490	0.61
40	100	0.21	28.0		3397	490	0.56
93	7.5	4.0	373.3	RV 063	1873	395	0.91
97	10	3.2	280.0		2061	463	0.89
103	15	2.3	186.7		2359	492	0.88
100	20	1.7	140.0		2597	538	0.86
92	25	1.3	112.0		2797	593	0.83
120	30	1.5	93.3		2973	700	0.78
108	40	1.1	70.0		3272	700	0.72
100	50	0.83	56.0		3524	700	0.71
95	60	0.68	46.7		3745	700	0.68
85	80	0.49	35.0		4122	700	0.64
74	100	0.37	28.0		4440	700	0.59
130	7.5	5.6	373.3	RV 075	2210	560	0.91
145	10	4.7	280.0		2433	703	0.90
150	15	3.4	186.7		2785	727	0.86
160	20	2.8	140.0		3065	872	0.84
150	25	2.1	112.0		3302	980	0.84
170	30	2.1	93.3		3509	980	0.79
165	40	1.6	70.0		3862	980	0.76
150	50	1.2	56.0		4160	980	0.73

Performance (n1= 2800)

M2 (Nm)	i	P1 (kW)	n2 (1/min)	Size	Fr2 (N)	Fr1 (N)	η
145	60	1.0	46.7	RV 075	4421	980	0.71
130	80	0.72	35.0		4865	980	0.66
120	100	0.58	28.0		5241	980	0.61
210	7.5	8.9	373.3	RV 090	2446	715	0.92
235	10	7.7	280.0		2692	900	0.89
270	15	6.0	186.7		3081	1034	0.88
260	20	4.4	140.0		3391	1120	0.87
250	25	3.4	112.0		3653	1270	0.86
310	30	3.7	93.3		3882	1270	0.82
275	40	2.6	70.0		4273	1270	0.78
265	50	2.0	56.0		4603	1270	0.78
245	60	1.6	46.7		4891	1270	0.75
225	80	1.2	35.0		5383	1270	0.69
200	100	0.9	28.0		5799	1270	0.65
391	7.5	16.6	373.3	RV 110	3090	950	0.92
437	10	14.1	280.0		3401	1194	0.91
489	15	10.7	186.7		3893	1337	0.89
483	20	8.0	140.0		4285	1485	0.89
506	25	6.8	112.0		4616	1700	0.87
552	30	6.5	93.3		4905	1700	0.83
529	40	4.7	70.0		5399	1700	0.82
495	50	3.7	56.0		5816	1700	0.78
473	60	3.0	46.7		6181	1700	0.77
399	80	2.0	35.0		6803	1700	0.73
368	100	1.6	28.0		7328	1700	0.67
520	7.5	22.1	373.3	RV 130	4042	1190	0.92
580	10	18.7	280.0		4449	1493	0.91
670	15	14.7	186.7		5092	1725	0.89
660	20	11.0	140.0		5605	1912	0.88
670	25	9.0	112.0		6038	2100	0.87
770	30	9.0	93.3		6416	2100	0.84
730	40	6.5	70.0		7062	2100	0.82
700	50	5.1	56.0		7607	2100	0.80
640	60	4.0	46.7		8084	2100	0.78
590	80	3.0	35.0		8897	2100	0.72
520	100	2.2	28.0		9584	2100	0.69
840	7.5	35.7	373.3	RV 150	5526	1550	0.92
885	10	28.4	280.0		6082	1848	0.91
910	15	19.8	186.7		6962	1889	0.90
980	20	16.1	140.0		7663	2289	0.89
890	25	12.0	112.0		8254	2494	0.87
920	30	10.5	93.3		8771	2800	0.86
1200	40	10.6	70.0		9654	2800	0.83
1100	50	8.1	56.0		10400	2800	0.80
990	60	6.2	46.7		11051	2800	0.78
920	80	4.6	35.0		12163	2800	0.73
810	100	3.3	28.0		13103	2800	0.72

Performance (n1 = 1400)

M2 (Nm)	i	P1 (kW)	n2 (1/min)	Size	Fr2 (N)	Fr1 (N)	η
18	5	0.61	280.0	RV 030	597	150	0.87
18	7.5	0.41	186.7		683	150	0.86
18	10	0.32	140.0		752	169	0.82
18	15	0.23	93.3		861	169	0.76
18	20	0.18	70.0		948	190	0.73
21	25	0.18	56.0		1021	210	0.68
20	30	0.15	46.7		1085	210	0.65
18	40	0.11	35.0		1194	210	0.60
17	50	0.09	28.0		1286	210	0.55
16	60	0.08	23.3		1367	210	0.49
13	80	0.05	17.5		1504	210	0.48
34	5	1.1	280.0	RV 040	1149	250	0.91
40	7.5	0.90	186.7		1315	294	0.87
40	10	0.69	140.0		1447	331	0.85
40	15	0.48	93.3		1657	331	0.81
39	20	0.37	70.0		1824	350	0.77
38	25	0.30	56.0		1964	350	0.74
45	30	0.31	46.7		2087	350	0.71
41	40	0.23	35.0		2298	350	0.65
39	50	0.18	28.0		2475	350	0.64
36	60	0.15	23.3		2630	350	0.59
33	80	0.12	17.5		2895	350	0.50
29	100	0.09	14.0		3118	350	0.47
62	5	2.0	280.0	RV 050	1577	350	0.91
71	7.5	1.6	186.7		1805	401	0.87
72	10	1.2	140.0		1987	490	0.88
74	15	0.88	93.3		2274	490	0.82
73	20	0.68	70.0		2503	490	0.79
70	25	0.54	56.0		2696	490	0.76
84	30	0.57	46.7		2865	490	0.72
76	40	0.42	35.0		3153	490	0.66
73	50	0.34	28.0		3397	490	0.63
68	60	0.28	23.3		3610	490	0.59
65	80	0.22	17.5		3973	490	0.54
55	100	0.16	14.0		4280	490	0.50
128	7.5	2.8	186.7	RV 063	2359	500	0.89
130	10	2.2	140.0		2597	571	0.87
140	15	1.6	93.3		2973	615	0.86
135	20	1.2	70.0		3272	667	0.82
130	25	1.0	56.0		3524	700	0.76
160	30	1.1	46.7		3745	700	0.71
145	40	0.76	35.0		4122	700	0.70
135	50	0.60	28.0		4440	700	0.66
130	60	0.51	23.3		4719	700	0.62
122	80	0.39	17.5		5193	700	0.57
118	100	0.34	14.0		5595	700	0.51
185	7.5	4.1	186.7	RV 075	2785	700	0.88
195	10	3.2	140.0		3065	830	0.89
200	15	2.3	93.3		3509	851	0.85
210	20	1.9	70.0		3862	980	0.81
200	25	1.5	56.0		4160	980	0.78
230	30	1.5	46.7		4421	980	0.75
220	40		35.0		4865	980	0.73
210	50	0.89	28.0		5241	980	0.69

Performance (n1 = 1400)

M2 (Nm)	i	P1 (kW)	n2 (1/min)	Size	Fr2 (N)	Fr1 (N)	η
200	60	0.75	23.3	RV 075	5569	980	0.65
190	80	0.58	17.5		6130	980	0.60
180	100	0.48	14.0		6603	980	0.55
290	7.5	6.3	186.7	RV 090	3081	900	0.90
310	10	5.1	140.0		3391	1082	0.89
360	15	4.1	93.3		3882	1257	0.86
355	20	3.1	70.0		4273	1270	0.84
340	25	2.4	56.0		4603	1270	0.83
410	30	2.6	46.7		4891	1270	0.77
360	40	1.8	35.0		5383	1270	0.73
340	50	1.4	28.0		5799	1270	0.71
320	60	1.1	23.3		6163	1270	0.71
285	80	0.83	17.5		6783	1270	0.63
270	100	0.67	14.0		7306	1270	0.59
552	7.5	12.0	186.7	RV 110	3893	1200	0.90
598	10	9.8	140.0		4285	1463	0.89
656	15	7.5	93.3		4905	1604	0.85
644	20	5.6	70.0		5399	1700	0.84
679	25	4.7	56.0		5816	1700	0.85
725	30	4.5	46.7		6181	1700	0.79
702	40	3.3	35.0		6803	1700	0.78
660	50	2.6	28.0		7328	1700	0.74
616	60	2.1	23.3		7787	1700	0.72
515	80	1.4	17.5		8571	1700	0.67
483	100	1.1	14.0		9232	1700	0.64
750	7.5	16.1	186.7	RV 130	5092	1500	0.91
820	10	13.5	140.0		5605	1845	0.89
920	15	10.3	93.3		6416	2070	0.87
910	20	7.8	70.0		7062	2100	0.86
930	25	6.5	56.0		7607	2100	0.84
1040	30	6.4	46.7		8084	2100	0.79
1050	40	4.9	35.0		8897	2100	0.79
980	50	3.8	28.0		9584	2100	0.76
900	60	3.1	23.3		10185	2100	0.71
840	80	2.3	17.5		11210	2100	0.67
740	100	1.7	14.0		12076	2100	0.64
1200	7.5	25.8	186.7	RV 150	6962	1950	0.91
1240	10	20.2	140.0		7663	2267	0.90
1250	15	13.9	93.3		8771	2285	0.88
1300	20	11.1	70.0		9654	2674	0.86
1200	25	8.4	56.0		10400	2800	0.84
1200	30	7.1	46.7		11051	2800	0.83
1550	40	7.3	35.0		12163	2800	0.78
1400	50	5.4	28.0		13103	2800	0.76
1260	60	4.2	23.3		13925	2800	0.73
1150	80	3.1	17.5		15325	2800	0.68
1000	100	2.3	14.0		16508	2800	0.64

Performance (n1 = 900)

M2 (Nm)	i	P1 (kW)	n2 (1/min)	Size	Fr2 (N)	Fr1 (N)	η
20	5	0.44	180.0	RV 030	692	175	0.86
20	7.5	0.30	120.0		792	175	0.84
20	10	0.24	90.0		871	197	0.79
20	15	0.17	60.0		997	197	0.74
20	20	0.13	45.0		1098	210	0.72
23	25	0.14	36.0		1183	210	0.62
21	30	0.11	30.0		1257	210	0.60
20	40	0.09	22.5		1383	210	0.52
18	50	0.07	18.0		1490	210	0.48
17	60	0.06	15.0		1583	210	0.45
15	80	0.04	11.3	1743	210	0.44	
40	5	0.87	180.0	RV 040	1331	290	0.87
44	7.5	0.65	120.0		1524	319	0.85
44	10	0.50	90.0		1677	350	0.83
45	15	0.36	60.0		1920	350	0.79
44	20	0.28	45.0		2113	350	0.74
43	25	0.23	36.0		2276	350	0.70
49	30	0.23	30.0		2419	350	0.67
45	40	0.17	22.5		2662	350	0.62
42	50	0.14	18.0		2868	350	0.57
39	60	0.11	15.0		3047	350	0.56
35	80	0.09	11.3	3354	350	0.46	
32	100	0.07	9.0	3490	350	0.43	
75	5	1.6	180.0	RV 050	1827	400	0.88
84	7.5	1.2	120.0		2091	448	0.88
84	10	0.94	90.0		2302	490	0.84
84	15	0.67	60.0		2635	490	0.79
77	20	0.48	45.0		2900	490	0.76
75	25	0.39	36.0		3124	490	0.72
90	30	0.42	30.0		3320	490	0.67
82	40	0.31	22.5		3654	490	0.62
77	50	0.25	18.0		3936	490	0.58
72	60	0.21	15.0		4183	490	0.54
68	80	0.16	11.3	4604	490	0.50	
56	100	0.12	9.0	4840	490	0.44	
151	7.5	2.2	120.0	RV 063	2734	580	0.86
153	10	1.7	90.0		3009	661	0.85
155	15	1.2	60.0		3444	670	0.81
148	20	0.91	45.0		3791	700	0.77
137	25	0.69	36.0		4084	700	0.75
175	30	0.79	30.0		4339	700	0.70
160	40	0.58	22.5		4776	700	0.65
145	50	0.45	18.0		5145	700	0.61
138	60	0.37	15.0		5467	700	0.59
128	80	0.29	11.3		6018	700	0.52
124	100	0.25	9.0	6270	700	0.47	
215	7.5	3.1	120.0	RV 075	3227	810	0.87
230	10	2.5	90.0		3551	975	0.87
235	15	1.8	60.0		4065	980	0.82
235	20	1.4	45.0		4474	980	0.79
215	25	1.1	36.0		4820	980	0.74
260	30	1.1	30.0		5122	980	0.74
240	40	0.83	22.5		5637	980	0.68
220	50	0.65	18.0		6073	980	0.64

Performance (n1 = 900)

M2 (Nm)	i	P1 (kW)	n2 (1/min)	Size	Fr2 (N)	Fr1 (N)	η
210	60	0.54	15.0	RV 075	6453	980	0.61
200	80	0.43	11.3		7103	980	0.55
190	100	0.35	9.0		7380	980	0.50
340	7.5	4.8	120.0	RV 090	3570	1040	0.89
370	10	4.0	90.0		3929	1270	0.87
420	15	3.1	60.0		4498	1270	0.85
390	20	2.3	45.0		4951	1270	0.80
370	25	1.8	36.0		5333	1270	0.77
460	30	1.9	30.0		5667	1270	0.76
410	40	1.4	22.5		6238	1270	0.69
390	50	1.1	18.0		6719	1270	0.67
350	60	0.86	15.0		7140	1270	0.64
315	80	0.63	11.3		7859	1270	0.59
280	100	0.49	9.0	8180	1270	0.54	
650	7.5	9.2	120.0	RV 110	4511	1390	0.89
713	10	7.6	90.0		4965	1700	0.88
759	15	5.6	60.0		5684	1700	0.85
725	20	4.1	45.0		6256	1700	0.83
759	25	3.5	36.0		6739	1700	0.82
840	30	3.5	30.0		7161	1700	0.75
794	40	2.5	22.5		7882	1700	0.75
748	50	2.0	18.0		8491	1700	0.70
682	60	1.6	15.0		9023	1700	0.67
567	80	1.1	11.3		9931	1700	0.61
515	100	0.84	9.0	10320	1700	0.58	
880	7.5	12.3	120.0	RV 130	5901	1740	0.90
960	10	10.3	90.0		6494	2100	0.88
1060	15	7.8	60.0		7434	2100	0.85
1040	20	5.8	45.0		8182	2100	0.84
1050	25	4.8	36.0		8814	2100	0.82
1170	30	4.7	30.0		9366	2100	0.78
1100	40	3.5	22.5		10309	2100	0.74
1050	50	2.7	18.0		11105	2100	0.73
940	60	2.1	15.0		11801	2100	0.70
860	80	1.6	11.3		12989	2100	0.63
780	100	1.2	9.0	13500	2100	0.61	
1400	7.5	19.5	120.0	RV 150	8067	2270	0.90
1480	10	15.7	90.0		8878	2700	0.89
1450	15	10.5	60.0		10163	2645	0.87
1500	20	8.4	45.0		11186	2800	0.84
1380	25	6.3	36.0		12050	2800	0.83
1400	30	5.4	30.0		12805	2800	0.81
1800	40	5.7	22.5		14094	2800	0.74
1600	50	4.1	18.0		15182	2800	0.74
1440	60	3.2	15.0		16133	2800	0.71
1300	80	2.4	11.3		17757	2800	0.64
1150	100	1.8	9.0	18000	2800	0.60	

Performance (n1 = 500)

M2 (Nm)	i	P1 (kW)	n2 (1/min)	Size	Fr2 (N)	Fr1 (N)	η
24	5	0.30	100.0	RV 030	841	210	0.84
24	7.5	0.21	66.7		963	210	0.80
24	10	0.16	50.0		1060	210	0.79
24	15	0.12	33.3		1213	210	0.70
23	20	0.09	25.0		1336	210	0.67
29	25	0.10	20.0		1439	210	0.61
26	30	0.08	16.7		1529	210	0.57
23	40	0.06	12.5		1683	210	0.50
21	50	0.05	10.0		1813	210	0.44
19	60	0.04	8.3		1830	210	0.41
17	80	0.03	6.3		1830	210	0.37
49	5	0.60	100.0	RV 040	1619	350	0.86
54	7.5	0.45	66.7		1853	350	0.84
54	10	0.35	50.0		2040	350	0.81
55	15	0.26	33.3		2335	350	0.74
52	20	0.19	25.0		2570	350	0.72
49	25	0.15	20.0		2769	350	0.68
58	30	0.16	16.7		2942	350	0.63
53	40	0.12	12.5		3238	350	0.58
49	50	0.10	10.0		3488	350	0.51
46	60	0.08	8.3		3490	350	0.50
40	80	0.06	6.3		3490	350	0.44
36	100	0.05	5.0		3490	350	0.38
92	5	1.1	100.0	RV 050	2222	490	0.88
103	7.5	0.86	66.7		2544	490	0.84
103	10	0.67	50.0		2800	490	0.80
103	15	0.47	33.3		3205	490	0.76
93	20	0.33	25.0		3528	490	0.74
91	25	0.28	20.0		3800	490	0.68
108	30	0.29	16.7		4038	490	0.65
98	40	0.22	12.5		4445	490	0.58
91	50	0.17	10.0		4788	490	0.56
83	60	0.14	8.3		4840	490	0.52
75	80	0.11	6.3		4840	490	0.45
65	100	0.09	5.0		4840	490	0.38
184	7.5	1.5	66.7	RV 063	3325	700	0.86
185	10	1.2	50.0		3660	700	0.81
187	15	0.85	33.3		4190	700	0.77
178	20	0.63	25.0		4611	700	0.74
164	25	0.48	20.0		4967	700	0.72
200	30	0.54	16.7		5279	700	0.65
185	40	0.40	12.5		5810	700	0.61
173	50	0.32	10.0		6259	700	0.57
160	60	0.26	8.3		6270	700	0.54
137	80	0.19	6.3		6270	700	0.47
128	100	0.16	5.0		6270	700	0.42
260	7.5	2.1	66.7	RV 075	3925	980	0.86
270	10	1.7	50.0		4320	980	0.83
280	15	1.2	33.3		4945	980	0.81
285	20	0.98	25.0		5443	980	0.76
255	25	0.73	20.0		5863	980	0.73
300	30	0.77	16.7		6231	980	0.68
280	40	0.58	12.5		6858	980	0.63
250	50	0.44	10.0		7380	980	0.59

Performance (n1 = 500)

M2 (Nm)	i	P1 (kW)	n2 (1/min)	Size	Fr2 (N)	Fr1 (N)	η
240	60	0.37	8.3	RV 075	7380	980	0.57
215	80	0.29	6.3		7380	980	0.49
210	100	0.24	5.0		7380	980	0.46
410	7.5	3.3	66.7	RV 090	4343	1270	0.87
435	10	2.7	50.0		4780	1270	0.84
490	15	2.1	33.3		5472	1270	0.81
470	20	1.6	25.0		6022	1270	0.77
440	25	1.2	20.0		6487	1270	0.77
550	30	1.4	16.7		6894	1270	0.69
480	40	0.95	12.5		7588	1270	0.66
450	50	0.75	10.0		8174	1270	0.63
400	60	0.59	8.3		8180	1270	0.59
365	80	0.45	6.3		8180	1270	0.53
330	100	0.35	5.0		8180	1270	0.49
794	7.5	6.4	66.7	RV 110	5488	1700	0.87
851	10	5.2	50.0		6040	1700	0.86
909	15	3.9	33.3		6914	1700	0.81
863	20	2.8	25.0		7610	1700	0.81
909	25	2.4	20.0		8198	1700	0.79
1000	30	2.4	16.7		8711	1700	0.73
932	40	1.7	12.5		9588	1700	0.72
880	50	1.4	10.0		10320	1700	0.66
781	60	1.1	8.3		10320	1700	0.62
662	80	0.76	6.3		10320	1700	0.57
599	100	0.59	5.0		10320	1700	0.53
1080	7.5	8.6	66.7	RV 130	7178	2100	0.88
1160	10	7.1	50.0		7900	2100	0.86
1300	15	5.5	33.3		9043	2100	0.83
1230	20	4.0	25.0		9953	2100	0.80
1200	25	3.2	20.0		10722	2100	0.79
1400	30	3.3	16.7		11394	2100	0.74
1300	40	2.4	12.5		12540	2100	0.71
1220	50	1.9	10.0		13500	2100	0.67
1070	60	1.5	8.3		13500	2100	0.62
970	80	1.1	6.3		13500	2100	0.58
860	100	0.85	5.0		13500	2100	0.53
1700	7.5	13.5	66.7	RV 150	9812	2800	0.88
1780	10	10.7	50.0		10800	2800	0.87
1730	15	7.2	33.3		12363	2800	0.84
1820	20	5.9	25.0		13607	2800	0.81
1630	25	4.3	20.0		14658	2800	0.79
1670	30	3.8	16.7		15576	2800	0.77
2120	40	3.9	12.5		17144	2800	0.71
1870	50	2.9	10.0		18000	2800	0.68
1680	60	2.3	8.3		18000	2800	0.64
1530	80	1.7	6.3		18000	2800	0.59
1350	100	1.3	5.0		18000	2800	0.54

Performance (n1 = 1400)

M2 (Nm)	i	P1 (kW)	n2 (1/min)	Size	Fr2 (N)	Fr1 (N)	η
73	300	0.08	4.7	RV 030/040	3490	210	0.45
65	400	0.06	3.5		3490	210	0.40
61	500	0.04	2.8		3490	210	0.45
73	600	0.04	2.3		3490	210	0.45
73	750	0.04	1.9		3490	210	0.36
73	900	0.03	1.6		3490	210	0.40
65	1200	0.02	1.2		3490	210	0.40
73	1500	0.02	0.93		3490	210	0.36
73	1800	0.02	0.78		3490	210	0.30
65	2400	0.01	0.58		3490	210	0.40
65	3200	0.01	0.44		3490	210	0.30
33	4000	0.01	0.35		3490	210	0.12
29	5000	0.01	0.28		3490	210	0.09
145	300	0.15	4.7	RV 030/050	4840	210	0.47
124	400	0.10	3.5		4840	210	0.45
120	500	0.09	2.8		4840	210	0.39
145	600	0.08	2.3		4840	210	0.44
145	750	0.07	1.9		4840	210	0.40
145	900	0.06	1.6		4840	210	0.39
124	1200	0.04	1.2		4840	210	0.38
145	1500	0.04	0.93		4840	210	0.35
145	1800	0.04	0.78		4840	210	0.30
124	2400	0.03	0.58		4840	210	0.25
120	3000	0.02	0.47		4840	210	0.29
82	4000	0.02	0.35		4840	210	0.15
82	4800	0.02	0.29		4840	210	0.13
230	300	0.24	4.7	RV 030/063	6270	210	0.47
230	400	0.19	3.5		6270	210	0.44
216	500	0.15	2.8		6270	210	0.42
230	600	0.13	2.3		6270	210	0.43
216	750	0.11	1.9		6270	210	0.38
198	900	0.09	1.6		6270	210	0.36
230	1200	0.08	1.2		6270	210	0.35
216	1500	0.06	0.93		6270	210	0.35
198	1800	0.05	0.78		6270	210	0.32
230	2400	0.05	0.58		6270	210	0.28
216	3000	0.04	0.47		6270	210	0.26
172	4000	0.03	0.35		6270	210	0.21
150	5000	0.02	0.28		6270	210	0.22
390	300	0.36	4.7	RV 040/075	7380	350	0.53
360	400	0.27	3.5		7380	350	0.49
320	500	0.21	2.8		7380	350	0.45
390	600	0.19	2.3		7380	350	0.50
390	750	0.16	1.9		7380	350	0.48
390	900	0.14	1.6		7380	350	0.45
360	1200	0.11	1.2		7380	350	0.40
390	1500	0.10	0.93		7380	350	0.38
390	1800	0.09	0.78		7380	350	0.35
360	2400	0.07	0.58		7380	350	0.31
320	3000	0.05	0.47		7380	350	0.31
250	4000	0.04	0.35		7380	350	0.23
250	5000	0.03	0.28		7380	350	0.24
610	300	0.56	4.7	RV 040/090	8180	350	0.53
610	400	0.43	3.5		8180	350	0.52

Performance (n1 = 1400)

M2 (Nm)	i	P1 (kW)	n2 (1/min)	Size	Fr2 (N)	Fr1 (N)	η
560	500	0.34	2.8	RV 040/090	8180	350	0.48
610	600	0.30	2.3		8180	350	0.50
560	750	0.23	1.9		8180	350	0.48
505	900	0.19	1.6		8180	350	0.43
610	1200	0.17	1.2		8180	350	0.44
560	1500	0.14	0.93		8180	350	0.39
505	1800	0.11	0.78		8180	350	0.37
610	2400	0.11	0.58		8180	350	0.34
560	3000	0.08	0.47		8180	350	0.34
460	4000	0.08	0.35		8180	350	0.21
410	5000	0.06	0.28		8180	350	0.20
1265	300	1.1	4.7	RV 050/110	10320	490	0.56
1185	400	0.79	3.5		10320	490	0.55
1100	500	0.61	2.8		10320	490	0.53
1185	600	0.55	2.3		10320	490	0.53
1265	750	0.49	1.9		10320	490	0.50
1265	900	0.43	1.6		10320	490	0.48
1185	1200	0.31	1.2		10320	490	0.47
1265	1500	0.30	0.93		10320	490	0.41
1265	1800	0.26	0.78		10320	490	0.40
1185	2400	0.19	0.58		10320	490	0.38
1100	3000	0.15	0.47		10320	490	0.36
819	4000	0.13	0.35		10320	490	0.23
746	5000	0.10	0.28		10320	490	0.22
1760	300	1.5	4.7	RV 063/130	13500	700	0.57
1650	400	1.1	3.5		13500	700	0.55
1550	500	0.86	2.8		13500	700	0.53
1650	600	0.76	2.3		13500	700	0.53
1760	750	0.66	1.9		13500	700	0.52
1760	900	0.58	1.6		13500	700	0.49
1650	1200	0.43	1.2		13500	700	0.47
1760	1500	0.39	0.93		13500	700	0.44
1760	1800	0.35	0.78		13500	700	0.41
1650	2400	0.25	0.58		13500	700	0.40
1550	3000	0.20	0.47		13500	700	0.38
1220	4000	0.15	0.35		13500	700	0.30
1100	5000	0.11	0.28		13500	700	0.29
2340	150	3.4	9.3	RV 063/150	18000	700	0.67
2340	200	2.7	7.0		18000	700	0.64
2050	250	1.9	5.6		18000	700	0.63
2340	400	1.9	3.5		18000	700	0.45
2670	500	1.8	2.8		18000	700	0.43
2330	600	1.4	2.3		18000	700	0.41
2670	750	1.3	1.9		18000	700	0.40
2330	900	0.98	1.6		18000	700	0.39
2100	1200	0.71	1.2		18000	700	0.36
2670	1500	0.75	0.93		18000	700	0.35
2100	1800	0.44	0.78		18000	700	0.39
2670	2400	0.46	0.58		18000	700	0.35
2330	3000	0.34	0.47		18000	700	0.33
1880	4000	0.23	0.35		18000	700	0.30
1650	5000	0.18	0.28		18000	700	0.27

UD Series Stepless Variator

UD series stepless variator are widely used for conveying, ceramics, packing, chemical, textile, foodstuffs, medicine, printing, rubber, Machine-tools, and all kinds of automatic production lines, pipelines and assembly lines which need speed-regulation, etc. Its main features are follows:

1. High speed-regulating precision: up to 0.5" «1 rotation.
2. Large speed-changing range: The speed ratio ranges from 1/1.4 to 1/7.
3. High in strength and long in service life.
4. Smooth in driving, low in service life.
5. Convenient to regulate the speed, and compact in structure and small in volume.
6. Full in sealing and suitable for any environment.
7. Easy in adaptation: it can be combined with all kinds of speed reducers, as to achieve low stepless speed-changing.
8. Made of high-quality aluminium alloy diecast in to forming, good-looking in appearance, light in weight and it never gets rusty. (0.18 - 0.75 kw)
Cast Iron body from size 1.1 kw up to 7.5 kw

Structure

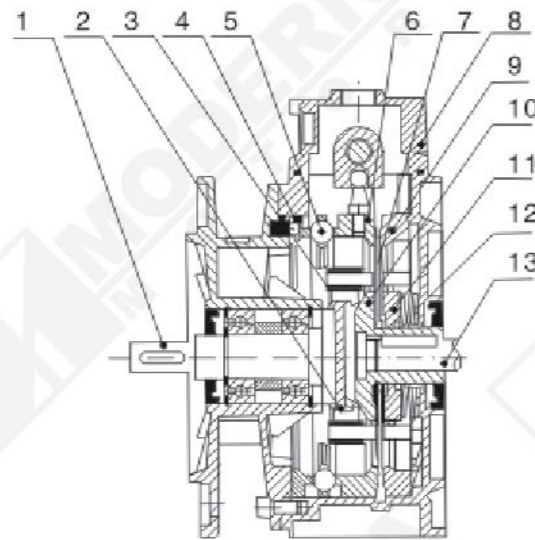

1. Output shaft
2. Planet carrier
3. Friction bearing-planet disk
4. Cam ring
5. Ball ring
6. Ajustable annulus ring
7. Planet disk
8. Control cover
9. Fixed annulus ring
10. Fixed sun race
11. Adjustable sun race
12. Belleville spring
13. Motor shaft

Variator Operation and Maintenance

1. Do not turn the hand wheel or adjust the speed when it's not running, it's inside parts will scratch and damage due to lack of lubrication at stand still adjustment.
2. Overload or Blockage running will cause the variator damage.
3. When running, the variator temperature will rising as follow :-
Run - In period (No-load) : the temperature may rising 40-50 °C higher than the environment. It's normal.
After 60-80 hours Run - In : the temperature will go down gradually untill about 20 °C higher than the environment.
The high temperature rise in running period will not affect it's internal parts and not cause or lower service life of part.
4. It's already filled with mineral oil (for B3), First draining and re-fill after 2,000 hrs then changing oil at every 4,000-5,000 hrs.
5. Always keep the oil at about 2/3 of the oil scale, Do not run when short of oil lubrication.
6. Loosing the air screw nut on the operating box when running, It's strictly forbidden to run without nut loosening.

Performance parameters

UD variator + 4 poles motors

Input	Type	Ratio	n ₂ (r/min)	Output	M ₂ (N.m)
0.18KW	UDL 0.18	1.6~8.2	880~170		1.5~3
0.37KW	UDL 0.37	1.4~7	1000~200		3~6
0.55KW	UDL 0.55	1.4~7	1000~200		4~8
0.75KW	UDL 0.75	1.4~7	1000~200		6~12
1.1KW	UD 1.1	1.4~7	1000~200		9~18
1.5KW	UD 1.5	1.4~7	1000~200		12~24
2.2KW	UD 2.2	1.4~7	1000~200		18~36
3.0KW	UD 3.0	1.4~7	1000~200		24~48
4.0KW	UD 4.0	1.4~7	1000~200		32~64
5.5KW	UD 5.5	1.4~7	1000~200		45~90
7.5KW	UD 7.5	1.4~7	1000~200		59~118

UD Variator + Build in Helical Gear + 4 Poles Motors

Input	Type	Ratio	n ₂ (r/min)	Output	M ₂ (N.m)
0.18KW 4P n ₁ =1400r/min	UDL 0.18-C	2.5	352~68		3.5~7.4
		3.3	266~51.5		4.7~10
		5	176~34		7~15
	UDL 0.18-2C	8	110~21		10~20
		11	80~15.5		14~28
		13.3	66~13		17~34
0.37KW 4P n ₁ =1400r/min	UDL 0.37-C	16.6	53~10		21~42
		20	44~8.5		25~50
		2.5	400~80		7.3~15
	UDL 0.37-2C	3.3	300~60		9.5~20
		5	200~40		15~30
		8	125~25		20~40
0.75KW 4P n ₁ =1400r/min	UDL 0.75-C	11	90~18		28~56
		13.3	75~15		34~68
		16.6	60~12		42~84
	UDL 0.75-2C	2.5	400~80		15~29
		3.3	300~60		19~38
		5	200~40		30~60
UDL 0.75-2C	8	125~25		40~80	
	11	90~18		54~108	
	13.3	75~15		68~136	
	UDL 0.75-2C	16.6	60~12		84~168
		20	50~10		96~140

Performance parameters of FRV/UD (worm-variator) series

Input	Size	Ratio	Output	
			n_2 (r/min)	M_2 (N.m)
P ₁ =0.18kw 4P n ₁ =1400r/min	40/0.18	7.5	117~22.7	9~18
	40/0.18	10	88~17	12~23
	40/0.18	15	58.7~11.3	17~32
	40/0.18	20	44~8.5	22~40
	40/0.18	25	35.2~6.8	27~47
	40/0.18	30	29.3~5.7	30~51
	40/0.18	40	22~4.3	37~62
	50/0.18	40	22~4.3	38~63
	50/0.18	50	17.6~3.4	43~60
	50/0.18	50	17.6~3.4	44~73
	50/0.18	60	14.7~2.8	50~80
	50/0.18	80	11~2.1	59~82
P ₁ =0.37kw 4P n ₁ =1400r/min	50/0.37	7.5	133~26.7	19~36
	50/0.37	10	100~20	25~47
	50/0.37	15	66.7~13.3	36~65
	50/0.37	20	50~10	46~82
	50/0.37	25	40~8	55~97
	50/0.37	30	33.3~6.7	61~107
	50/0.37	40	25~5	76~124
	63/0.37	40	25~5	79~134
	50/0.37	50	20~4	89~120
	63/0.37	50	20~4	92~155
	63/0.37	60	16.7~3.3	104~173
	63/0.37	80	12.5~2.5	125~173
P ₁ =0.55kw 4P n ₁ =1400r/min	63/0.55	7.5	133~26.7	26~49
	63/0.55	10	100~20	34~63
	63/0.55	15	66.7~13.3	48~88
	63/0.55	20	50~10	62~112
	63/0.55	25	40~8	75~133
	63/0.55	30	33.3~6.7	81~146
	63/0.55	40	25~5	105~179
	63/0.55	50	20~4	123~207
	75/0.55	50	20~4	129~216
	75/0.55	60	16.7~3.3	146~242
	75/0.55	80	12.5~2.5	176~250
	90/0.55	80	12.5~2.5	189~309
P ₁ =0.75kw 4P n ₁ =1400r/min	90/0.55	100	10~2	218~350
	63/0.75	7.5	133~26.7	39~73
	63/0.75	10	100~20	51~94
	63/0.75	15	66.7~13.3	72~132
	63/0.75	20	50~10	92~168
	63/0.75	25	40~8	112~199
	63/0.75	30	33.3~6.7	126~219
	63/0.75	40	25~5	156~232
	63/0.75	50	20~4	185~310
	75/0.75	50	20~4	192~320
	75/0.75	60	16.7~3.3	219~300
	90/0.75	60	16.7~3.3	230~389
P ₁ =1.1kw 4P n ₁ =1400r/min	90/0.75	80	12.5~2.5	265~428
	110/0.75	80	12.5~2.5	302~503
	90/0.75	100	10~2	303~410
	110/0.75	100	10~2	348~575
	75/1.1	7.5	133~26.7	59~111
	75/1.1	10	100~20	77~144
	90/1.1	10	100~20	78~146
	75/1.1	15	66.7~13.3	110~203
	90/1.1	15	66.7~13.3	113~208
	75/1.1	20	50~10	142~258
	90/1.1	20	50~10	146~266
	75/1.1	25	40~8	172~308
P ₁ =1.5kw 4P n ₁ =1400r/min	90/1.1	25	40~8	177~320
	75/1.1	30	33.3~6.7	195~340
	90/1.1	30	33.3~6.7	202~356
	75/1.1	40	25~5	245~360
	90/1.1	40	25~5	256~442

Input	Size	Ratio	Output		
			n_2 (r/min)	M_2 (N.m)	
P ₁ =1.1kw 4P n ₁ =1400r/min	90/1.1	50	20~4	304~517	
	110/1.1	50	20~4	320~550	
	110/1.1	60	16.7~3.3	368~625	
	130/1.1	60	16.7~3.3	373~623	
	110/1.1	80	12.5~2.5	455~754	
	130/1.1	80	12.5~2.5	460~749	
	110/1.1	100	10~2	522~710	
	130/1.1	100	10~2	531~868	
	P ₁ =1.5kw 4P n ₁ =1400r/min	75/1.5	7.5	133~26.7	78~148
		90/1.5	7.5	133~26.7	77~150
		75/1.5	10	100~20	102~192
		90/1.5	10	100~20	104~195
75/1.5		15	66.7~13.3	147~270	
90/1.5		15	66.7~13.3	150~277	
75/1.5		20	50~10	190~344	
90/1.5		20	50~10	194~355	
75/1.5		25	40~8	229~330	
90/1.5		25	40~8	236~427	
75/1.5		30	33.3~6.7	260~390	
90/1.5		30	33.3~6.7	270~474	
P ₁ =2.2kw 4P n ₁ =1400r/min	75/1.5	40	25~5	327~360	
	90/1.5	40	25~5	341~589	
	90/1.5	50	20~4	406~560	
	110/1.5	50	20~4	426~733	
	110/1.5	60	16.7~3.3	490~833	
	130/1.5	60	16.7~3.3	498~831	
	130/1.5	80	12.5~2.5	614~999	
	130/1.5	100	10~2	696~1100	
	110/2.2	7.5	133~26.7	120~226	
	110/2.2	10	100~20	157~294	
	110/2.2	15	66.7~13.3	228~418	
	110/2.2	20	50~10	298~549	
P ₁ =3.0kw 4P n ₁ =1400r/min	110/2.2	25	40~8	364~664	
	110/2.2	30	33.3~6.7	413~717	
	110/2.2	40	25~5	533~931	
	130/2.2	40	25~5	542~932	
	130/2.2	50	20~4	648~1097	
	130/2.2	60	16.7~3.3	746~1246	
	130/2.2	80	12.5~2.5	921~1499	
	130/2.2	100	10~2	1040~1100	
	110/3.0	7.5	133~26.7	160~302	
	130/3.0	7.5	133~26.7	160~301	
	110/3.0	10	100~20	210~392	
	130/3.0	10	100~20	211~395	
P ₁ =4.0kw 4P n ₁ =1400r/min	110/3.0	15	66.7~13.3	304~558	
	130/3.0	15	66.7~13.3	307~563	
	110/3.0	20	50~10	398~732	
	130/3.0	20	50~10	402~733	
	110/3.0	25	40~8	485~885	
	130/3.0	25	40~8	490~885	
	110/3.0	30	33.3~6.7	547~956	
	130/3.0	30	33.3~6.7	562~973	
	110/3.0	40	25~5	711~1030	
	130/3.0	40	25~5	720~1242	
	130/3.0	50	20~4	864~1463	
	110/4.0	7.5	133~26.7	213~402	
130/4.0	7.5	133~26.7	214~401		
110/4.0	10	100~20	279~523		
130/4.0	10	100~20	281~527		
110/4.0	15	66.7~13.3	405~744		
130/4.0	15	66.7~13.3	410~751		
110/4.0	20	50~10	530~975		
130/4.0	20	50~10	536~978		
110/4.0	25	40~8	647~1020		
130/4.0	25	40~8	653~1180		
130/4.0	30	33.3~6.7	749~1298		
130/4.0	40	25~5	960~1650		

UD basic model installation dimensions

B3 Model

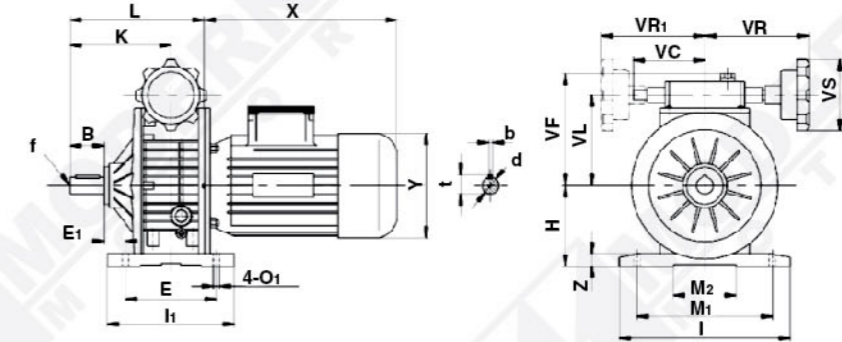

Type	B	d(j6)	E	E ₁	H	I	I ₁	K	L	M ₁	M ₂	O ₁	VC	VF	VL	VR	VR ₁	VS	b	f	t	X	Y	Z
UDL 0.18B3	23	11	105	17.5	80	145	120	87.5	135.5	110	71	9	71	111	78	110	110	85	4	-	12.5	200	120	10
UDL 0.37B3	30	14	104	20	93	149	125	104	140	120	96	9	71	123	90	110	110	85	5	M6	16	227	141	10
UDL 0.75B3	40	19	125	26	113	190	150	125.5	179	160	135	11	79	140	107	120	120	110	6	M6	21.5	268	160	15
UD 1.1B3	40	24	105	34.5	100	207	130	136	187	160	115	13	-	124	102	150	-	110	8	M8	27	265	195	15
UD 1.5B3	50	24	115	53.5	123	241	150	165	238	190	143	13	-	144	122	150	-	110	8	M8	27	290	195	18
UD 2.2B3	60	30	230	25	150	300	270	191	268	245	190	14	-	188	150	160	-	110	8	M8	33	320	215	25
UD 3.0B3	60	30	230	25	150	300	270	191	268	245	190	14	-	188	150	160	-	110	8	M8	33	320	215	25
UD 4.0B3	60	30	230	25	150	300	270	191	268	245	190	14	-	188	150	160	-	110	8	M8	33	340	240	25
UD 5.5B3	70	35	250	33	200	365	290	201	319	315	245	18	-	192	194	-	110	10	M10	38	395	275	30	
UD 7.5B3	70	35	250	33	200	365	290	201	319	315	245	18	-	192	194	-	110	10	M10	38	435	275	30	

B5 Model

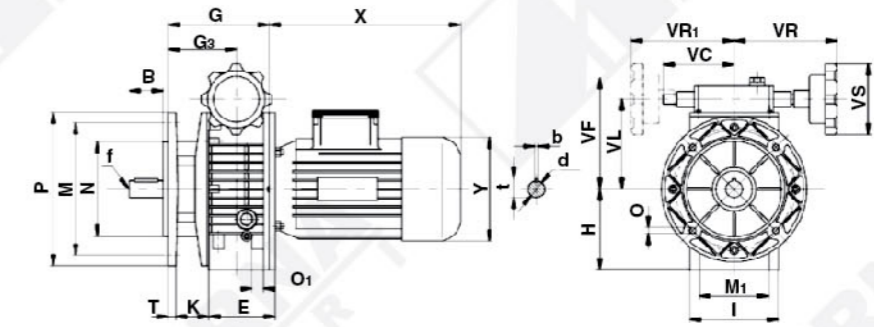

Type	B	d(j6)	E	G	G ₃	H	I	M	M ₁	N	D	D ₁	P	T	K	VC	VF	VL	VR	VR ₁	VS	b	f	t	X	Y
UDL 0.18B5	23	11	50	112.5	64.5	70	72	115	60	95	9	M6	140	3.5	46	71	111	78	110	110	85	4	-	12.5	200	120
UDL 0.37B5	30	14	40	110	74	80	90	130	77	110	9	M8	160	3.5	53	71	123	90	110	110	85	5	M6	16	227	141
UDL 0.75B5	40	19	58	139	85.5	100	98	165	84	130	11	M8	200	3.5	60	79	140	107	120	120	110	6	M6	21.5	268	160
UD 1.1B5	40	24	-	147	95	98	207	165	-	130	11	-	200	3.5	-	-	124	102	150	-	110	8	M8	27	265	195
UD 1.5B5	50	24	-	188	115	126	241	165	-	130	11	-	200	3.5	-	-	144	122	150	-	110	8	M8	27	290	195
UD 2.2B5	60	30	-	208	131	150	270	265	-	230	15	-	300	4	-	-	188	150	160	-	110	8	M8	33	320	215
UD 3.0B5	60	30	-	208	131	150	270	265	-	230	15	-	300	4	-	-	188	150	160	-	110	8	M8	33	320	215
UD 4.0B5	60	30	-	208	131	150	270	265	-	230	15	-	300	4	-	-	188	150	160	-	110	8	M8	33	340	240
UD 5.5B5	70	35	-	244	131	200	-	300	-	250	19	-	350	5	-	-	192	194	-	110	10	M10	38	395	275	
UD 7.5B5	70	35	-	244	131	200	-	300	-	250	19	-	350	5	-	-	192	194	-	110	10	M10	38	435	275	

Basic model-single stage gear reducer installation dimensions

B3 Model

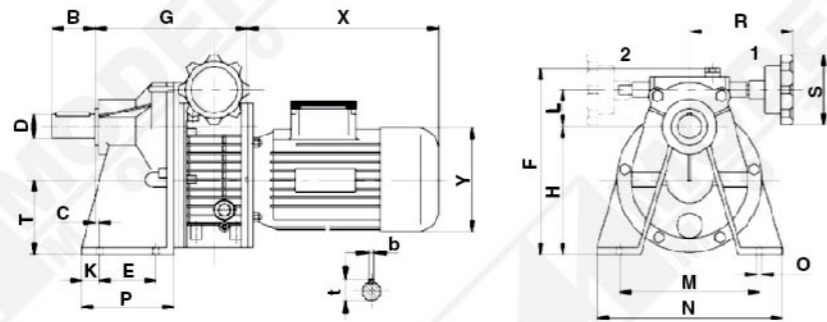

Type	B	C	D	t	b	E	F	G	H	Y	L	M	N	O	P	R	S	T	X	K
UDL0.18-CB3	40	18	19	21.5	6	45	162	189	108	120	33	115	130	9	80	110	85	66	200	16
UDL0.37-CB3	50	6	24	27	8	70	187	190	130	141	39	150	190	10	110	110	85	79	227	15
UDL0.75-CB3	60	7	28	31	8	70	228	225	160	160	46	165	210	12	130	130	110	99	268	25

B5 Model

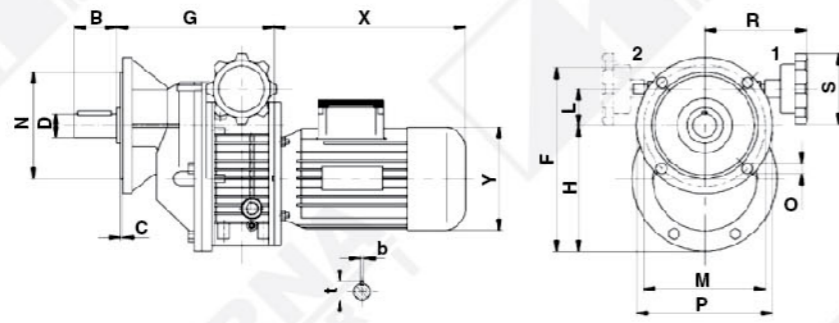

Type	B	C	D	t	b	F	G	H	Y	L	M	N	O	P	R	S	X
UDL0.18-CB5	40	3	19	21.5	6	176	191	105	120	33	115	95	9	140	110	85	200
UDL0.37-CB5	50	4	24	27	8	208	192	128	141	39	130	110	10.5	160	110	85	227
UDL0.75-CB5	60	4	28	31	8	255	227	155	160	46	165	130	12.5	200	130	110	268

Basic model-double stage gear reducer installation dimensions

B3 Model

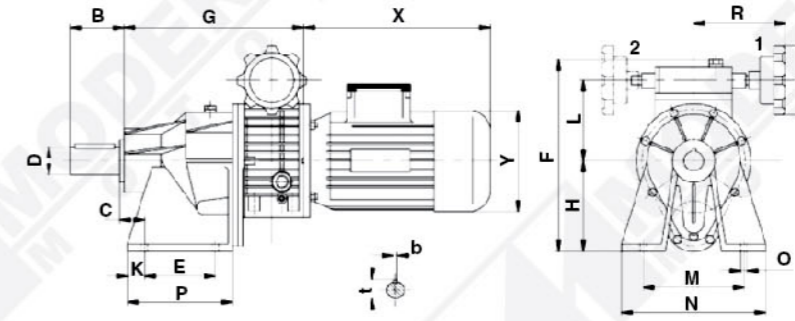

Type	B	C	D	t	b	E	F	G	H	Y	L	M	N	O	P	R	S	X	K
UDL0.18-2CB3	40	27	19	21.5	6	70	201	229	105	120	78	105	130	9	120	110	85	200	21
UDL0.37-2CB3	55	25	28	31	8	85	216	238	110	141	90	150	190	10	140	110	85	227	19
UDL0.75-2CB3	65	34	32	35	10	90	261	278	154	160	107	185	230	12	150	130	110	268	21

B5 Model

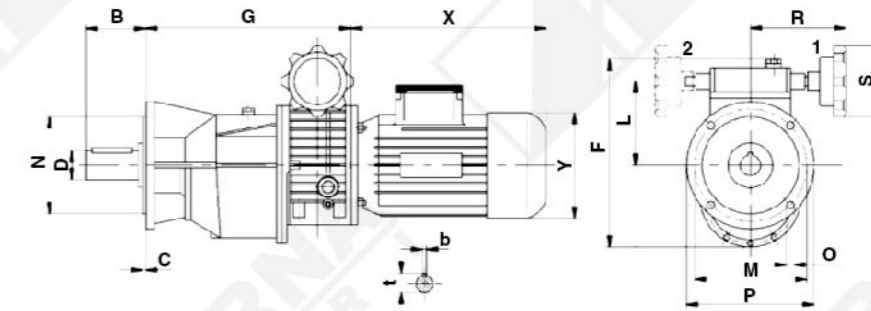

Type	B	C	D	t	b	F	G	Y	L	M	N	O	P	R	S	X
UDL0.18-2CB3	40	3	19	21.5	6	198	231	120	78	115	95	9	140	110	85	200
UDL0.37-2CB3	65	4	28	31	8	223	240	141	90	130	110	10.5	160	110	85	227
UDL0.75-2CB3	65	4	32	35	10	262	280	160	107	165	130	12.5	200	130	110	268

FRV/UD (worm-variator) series installation dimensions

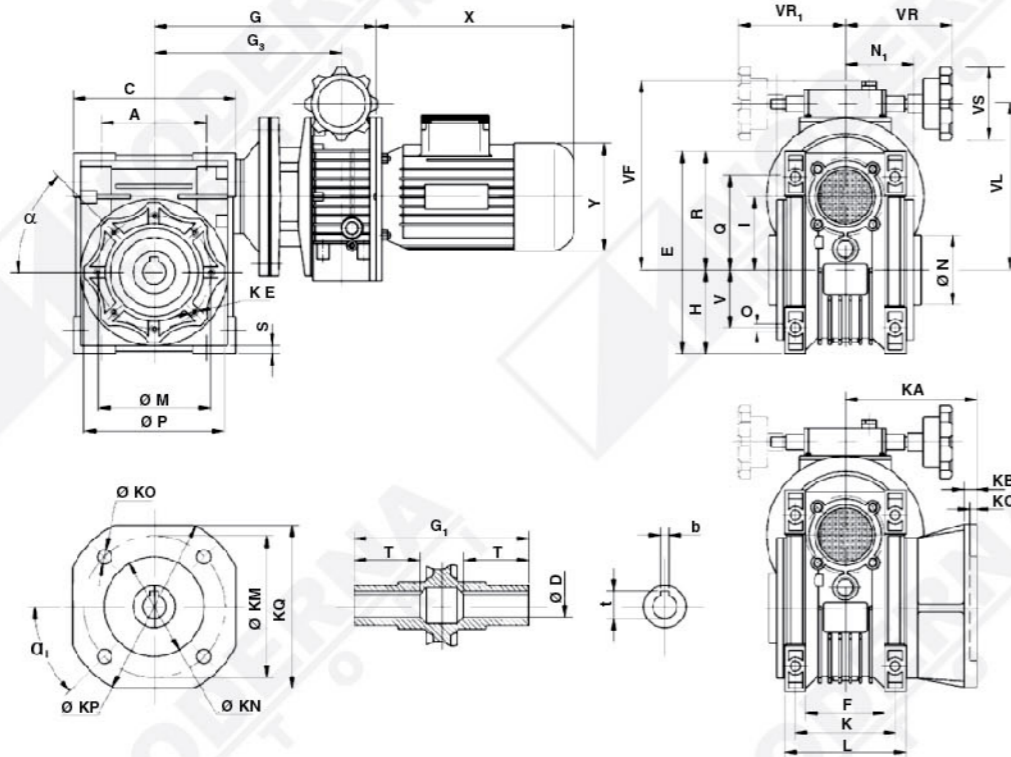

Size	a	a ₁	A	K	KC			KE	KM			KN(H8)			KO			M	N (h8)	N ₁	O	Q	S	V	b	D(H7)	t	T
					F	FB	FL		F	FB	FL	F	FB	FL	F	FB	FL											
40/0.18	45°	45°	70	60	4	5	4	M6x8(n,4)	87	115	87	60	95	60	9(n,4)	9.5(n,4)	9(n,4)	75	60	36.5	6.5	55	6.5	35	6(6)	18(19)	20.8(21.8)	26
50/0.18	45°	45°	80	70	5	5	5	M8x10(n,4)	90	130	90	70	110	70	11(n,4)	9.5(n,4)	11(n,4)	85	70	43.5	8.5	64	7	40	8(8)	25(24)	28.3(27.3)	30
50/0.37																												
63/0.37	45°	45°	100	85	6	5	6	M8x14(n,8)	150	165	150	115	130	115	11(n,4)	11(n,4)	11(n,4)	95	80	53	8.5	80	8	50	8(8)	25(28)	28.3(31.3)	36
63/0.55																												
63/0.75																												
75/0.37																												
75/0.55																												
75/0.75	120	90	6	-	-	M8x14(n,8)	165	-	-	130	-	-	14(n,4)	-	-	115	95	57	11	93	10	60	8	28(35)	31.3(38.3)	40		
75/1.1	45°	45°	140	100	6	-	-	M10x18(n,8)	175	-	-	152	-	14(n,4)	-	-	130	110	67	13	102	11	70	10	35(38)	38.3(41.3)	45	
75/1.5																												
90/0.55																												
90/0.75	45°	45°	170	115	6	-	-	M10x18(n,8)	230	-	-	170	-	14(n,8)	-	-	165	130	74	14	125	14	85	12	42	45.3	50	
90/1.1																												
90/1.5																												
110/1.1	45°	22.5°	200	120	6	-	-	M12x21(n,8)	255	-	-	180	-	16(n,8)	-	-	215	180	81	16	140	15	100	14	45	48.8	60	
110/1.5																												
110/2.2																												
110/3.0																												
110/4.0																												
130/1.5																												
130/2.2																												
130/3.0																												
130/4.0																												

Continuous

Size	C	E	F	G	G ₁	G ₃	H	I	KA			KB			KP			KQ			L	P	R	VF	VL	VS	VR	VR ₁
									F	FB	FL	F	FB	FL	F	FB	FL	F	FB	FL								
40/0.18	100	121.5	43	183	78	134	50	40	67	76.5	97	7	9	7	110	140	110	95	-	95	71	87	71.5	151	118	85	110	110
50/0.18	120	144	49	193	92	145	60	50	90	87.5	120	9	10	9	125	160	125	110	-	110	85	100	84	161	128	85	110	110
50/0.37				190		154																		173	140	85	110	110
63/0.37	144	174	67	205	112	169	72	63	82	99	112	10	11	10	180	200	180	142	-	142	103	110	102	186	153	85	110	110
63/0.55				234		181																		203	170	110	120	120
63/0.75				234		181																		203	170	110	120	120
75/0.37				223		187																		198	165	85	110	110
75/0.55				252		198																		215	182	110	120	120
75/0.75	172	205	72	252	120	198	86	75	111	-	-	13	-	-	200	-	-	170	-	-	112	140	119	215	182	110	120	120
75/1.1	208	238	74	259.5	140	207.5	103	90	111	-	-	13	-	-	210	-	-	200	-	-	130	160	135	199	177	110	150	-
75/1.5				300.5		227.5																		219	197	110	150	-
90/0.55				269		215																		230	197	110	120	120
90/0.75	269	215	230	197	110	120	120																					
90/1.1	276.5	224.5	214	192	110	150	-																					
90/1.5	317.5	244.5	234	212	110	150	-																					
110/1.1	252.5	295	-	307	155	255	128	110	131	-	-	15	-	-	280	-	-	260	-	-	144	200	168	234	212	110	120	-
110/1.5				348		275																		254	232	110	150	-
110/2.2				368		291																		298	260	110	160	-
110/3.0	368	291	298	260	110	160	-																					
110/4.0	368	291	298	260	110	160	-																					
130/1.5	292.5	335	-	368	170	295	148	130	140	-	-	15	-	-	320	-	-	290	-	-	155	250	188	274	252	110	150	-
130/2.2				388		311																		318	280	110	160	-
130/3.0				388		311																		318	280	110	160	-
130/4.0				388		311																		318	110	160	-	

Motor size

Frame No.	63	71	80	90S	90L	100L	100L	112M
4P/KW Power	0.18	0.37	0.75	1.1	1.5	2.2	3.0	4.0
X	200	227	268	265	290	320	320	340
Y	120	141	160	195	195	215	215	240

Lubrication

Manufacturer's recommended lubricants

	FRV 110 ÷ 150	FRV 025 ÷ 090 PC 63 ÷ 090	UD0.18-7.5
Lubricant	Mineral oil	Synthetic oil	Mineral oil
T °C	(-5)÷(+40)	(-25)÷(+50)	(-10) ÷ (+40)
ISO VG	ISO VG460	ISO VG320	ISO VG32
AGIP	BLASIA 460	TELIUM VSF320	BLASIA 32
SHELL	OMALA OIL460	TIVELA OIL S320	A.T.F. DEXRON
ESSO	SPARTAN EP460	S220	A.T.F. DEXRON
MOBIL	MOBIL SHC634	MOBIL SHC632	A.T.F. 220
CASTROL	ALPHA MAX 460	ALPHASYN PG320	DEXRON II
BP	ENERGOL GR-XP460	ENERGOL SG-XP320	AUTRAN DX

Oil capacities

FRV	025	030	040	050	063	075	090	110	130	150
B3								3	4.5	7
B8								2.2	3.3	5.1
B6 B7	0.02	0.04	0.08	0.15	0.3	0.55	1	2.5	3.5	5.4
V5								3	4.5	7
V6								2.2	3.3	5.1

PC	063	071	080	090
B3 B8				
B6 B7	0.05	0.07	0.15	0.16
V5 V6				

UD	0.18	0.37	0.75	1.1/1.5	2.2/3/4	5.5/7.5
B3 - B5 - B6 - B8	0.17	0.24	0.41	0.69	1.38	2.29
V1 - V5	0.24	0.38	0.78	1.23	2.46	4.10
V3 - V6	0.26	0.38	0.41	0.69	2.46	3.68

Quantity of oil in litres

1. Make sure that the reducer is located onto a flat and non-flexible surface and subject to any vibration be foreseen, it is advisable to fix the screw heads by means of cut washers.
2. For outdoor applications, provide suitable protections against the atmosphere and direct precipitation. For applications in humid environments, provide appropriate protections onto the reducer machined surfaces.
3. During mounting of pinions, couplings or pulleys onto the output shafts, try to avoid any impact by using the appropriate pullers located in the threaded holes at the end of the same shafts.
4. When reducer starts to work up to 150 hours, its lubricant should be replaced. After that, the cycle of oil replacement is about 4000 hours.
5. Lubricant should be kept enough in the casing and checked at a fixed time.
6. Avoid mixing synthetic and mineral lubricants.

B5 & B14 Motor Dimensions

MS56-132 B5

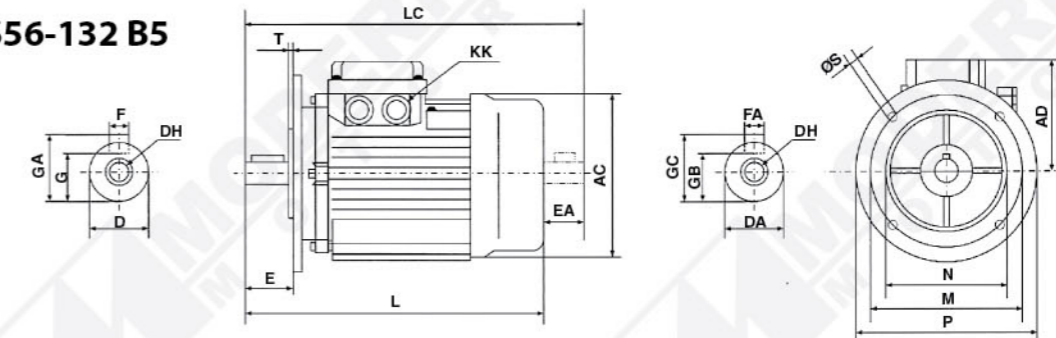

MS56-132 B14

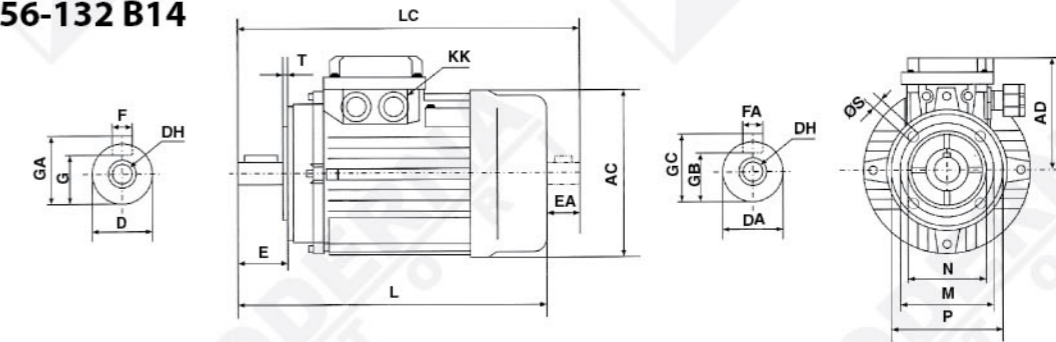

B 14

Frame	AC	AD	D	DH	E	F	G	KK	L	M	N	P	S	T	DA	EA	GC	GB	GA	FA	M	N	P
MS56	110	96	9	M4 x 12	20	3	7.2	2-M18 x 1.5	189	100	80	120	7	3	9	20	10.2	7.2	10.2	3	65	50	80
MS63	122	99	11	M4 x 12	23	4	8.5	2-M18 x 1.5	218	115	95	140	9	3	11	23	12.5	8.5	12.5	4	75	60	90
MS71	138	109	14	M5 x 12	30	5	11	2-M18 x 1.5	250	130	110	160	9	3.5	14	30	16	11	16	5	85	70	105
MS80	157	112	19	M6 x 16	40	6	15.5	2-M20 x 1.5	278	165	130	200	12	3.5	14	30	16	11	21.5	5	110	80	120
MS90S	175	120	24	M8 x 19	50	8	20	2-M20 x 1.5	335	165	130	200	12	3.5	19	40	21.5	15.5	27	6	115	95	140
MS90L	175	120	24	M8 x 19	50	8	20	2-M20 x 1.5	335	165	130	200	12	3.5	19	40	21.5	15.5	27	6	115	95	140
MS100L	196	139	28	M10 x 22	60	8	24	2-M20 x 1.5	377	215	180	250	15	4	28	60	31	24	31	8	130	110	160
MS112M	220	156	36	M10 x 22	60	8	24	2-M20 x 1.5	395	215	180	250	15	4	28	60	31	24	31	8	130	110	160
MS132S	260	185	38	M12 x 28	80	10	33	2-M25 x 1.5	472	265	230	300	15	4	38	80	41	33	41	10	165	130	200
MS132M	260	185	38	M12 x 28	80	10	33	2-M25 x 1.5	510	265	230	300	15	4	38	80	41	33	41	10	165	130	200